

# Quick Manual

## Digital Meter Relay, Model 452A DC Voltage & Current

I-01594T

### 1. Preface

Thank you for purchasing our digital meter relay 452A series.

Before use, read this manual carefully and thoroughly, and keep this manual available for routine reference.

Please check contents of the package you received as outlined below.

- (1) 452A itself (2) packing (3) This manual (4) Unit label (5) Indication label  
(6) Sensor power supply unit (Sensor power supply option) (7) Connector with 2m flat cable (BCD output option)

For safe use of this product, please observe the following warning and caution.

In order to help the users' safe use of the products, the following symbol marks are used in this manual.

**⚠ WARNING** This is the warning to avoid the danger when it is assumed that such danger as may cause fatal accident or severe injury to a user occurs in case that the product is mishandled.

**⚠ CAUTION** This is the caution to avoid the danger when it is assumed that such danger as may cause minor injury to a user or generate only physical obstacle occurs in case that the product is mishandled.

#### ⚠ WARNING

- There is no power on-off switch on the model 452A. It immediately starts to operate after turning the power.
- Do not touch terminals when turning the power on.

#### ⚠ CAUTION

Preserve followings for your safety.

- The rated data is, however, defines with more than 15 minutes warming-up times.
- When the product is installed in the cabinet, perform the appropriate heat radiation to keep less than 50 °C in it.
- Avoid the close-contacted mounting of the meter relay. The rise of internal temperature affects the life of product.
- Do not install under the following conditions.
  - Where it is exposed to direct sunlight, dust, corrosive gases, rain, etc.
  - Where ambient temperature or humidity is high.
  - Where it is exposed to excessive noise or static electricity.
  - Where there is constant vibration or shock
- Store the instrument within the specified temperature range for storage (-20~70°C).
- When the front panel or the case becomes dirty, wipe it with soft cloth.  
For heavy dirt, wipe it lightly with the soft cloth wetted with the neutral cleaner thinned by water, and finish the cleaning with dry cloth. Do not use organic solvent like benzene or paint thinner as they may deform or discolor the case.

## 2. Specifications

### 2.1 Installation Specifications

Power Supply	: AC 100 to 240V (90-250V) 50/60Hz, DC12 to 24V (9-32V), DC110V (100-170V)
Power Consumption	: 452A itself Approx. 9VA at 100VAC, 11.5VA at 200VAC, 400mA at 12VDC, 200mA at 24VDC, 40mA at 110VDC.
	Sensor power supply unit Approx. 7VA at 100VAC, 9VA at 200VAC, 200mA at 12VDC, 100mA at 24VDC, 30mA at 110VDC.
Comparator output	: Relay output 4-SPST (NO) for AL1 to AL4, and 1-SPDT for GO Contact capacity (resistive): AC250V 1A, DC30V 1A Min. 10 <sup>5</sup> electrical operation life (ON-OFF 1200 times / hr) Min. 20x10 <sup>6</sup> mechanical operation life (ON-OFF 18000 times / hr) Open Collector output 5-NPN for AL1 to AL4, and GO Contact rating: Max. DC30V 30mA, saturation voltage: Max. DC 1.6V
Operating Temperature	: 0 to 50°C
Storage Temperature	: -20 to 70°C
Weight	: Approx. 300g (60g of the sensor power supply unit)
Mounting Method	: Panel mount with the bracket

## 2.2 General Specifications

Display	: 0~99999, “-” polarity, with zero-suppress function. PV: red or green LED (character height 15.2mm) SV1 and SV2: red LED (character height 7.6mm)
Decimal Point	: Programmable (No external control).
Over-range indication	: Blinking with 130% display. When exceeded 99999, blinking with 00000. In case of 699.9V measuring, when exceeded 699.9V, blinking with full scale value.
Resolution	: 1/100000
Sampling rate	: Approx. 15 times / sec.
Noise Rejection	: Normal mode (NMR) - 50dB or more. Common mode (CMR) - 110dB or more.
Noise Through	: 1000V (at AC voltage power supply)
Power Supply Line	
Insulation Resistance	: DC500V 100MΩ or more.
Withstanding Voltage	: Input terminals - Case : AC2000V each for 1 min. Power supply terminals - Case : AC2000V each for 1 min. Power supply terminals - Input and output terminals : AC1500V each for 1min. Input terminals - Output terminals : AC500V each for 1 min.
Housing protection	: IP65 for the front panel, IP20 for the rear case, IP00 for terminals

## 3. Mounting

Insert the case with the suitable gasket from the panel front.  
 Fix the case using the mounting bracket.  
 Cut the panel to mount the case in accordance with the illustration.

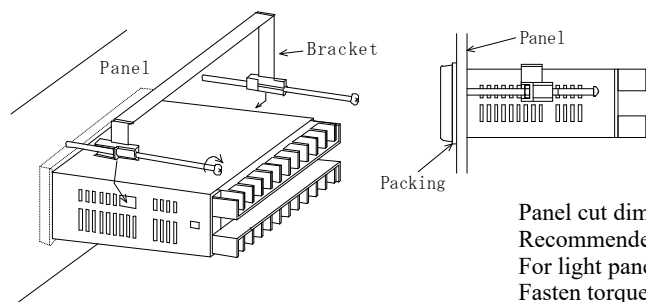

Panel cut dimension:  $92^{+0.8/0} \times 45^{+0.6/0}$  mm  
 Recommended panel thickness is 0.6 to 6mm.  
 For light panel, such as aluminum, should be 1.5mm or more to avoid deform.  
 Fasten torque of the mounting bracket is 0.2 to 0.3N·m.

### **⚠ CAUTION**

- Do not overtighten the mounting bracket.
- When plural mounting, pay attention to ventilation to cool down in the panel.

## 4. Nomenclature

### 4.1 Front panel

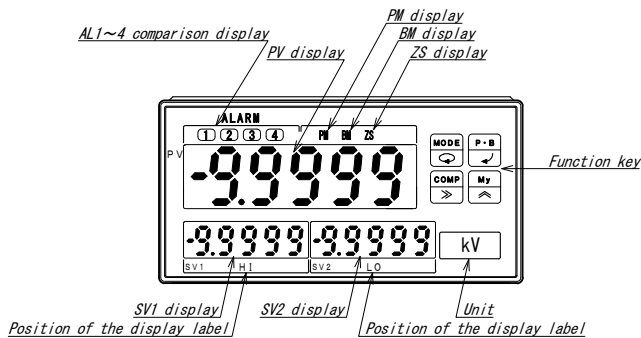

### 4.2 Function key

- MODE** (↻) ..... Switch the measuring, the parameter setting, and the calibration mode.
- MODE** (↻) ..... Switch modes during the parameter setting mode.
- P·B** (↵) ..... Switch indications during the measuring mode.
- P·B** (↵) ..... Enter the input value during the parameter setting mode.
- COMP** (➡) ..... Switch alarm points during the measuring mode.
- COMP** (➡) ..... Shift among the digits during the parameter setting mode.
- My** (⬆) ..... Switch to My mode during the measuring mode.
- My** (⬆) ..... Change values during the parameter setting mode.

### 4.3 Rear panel

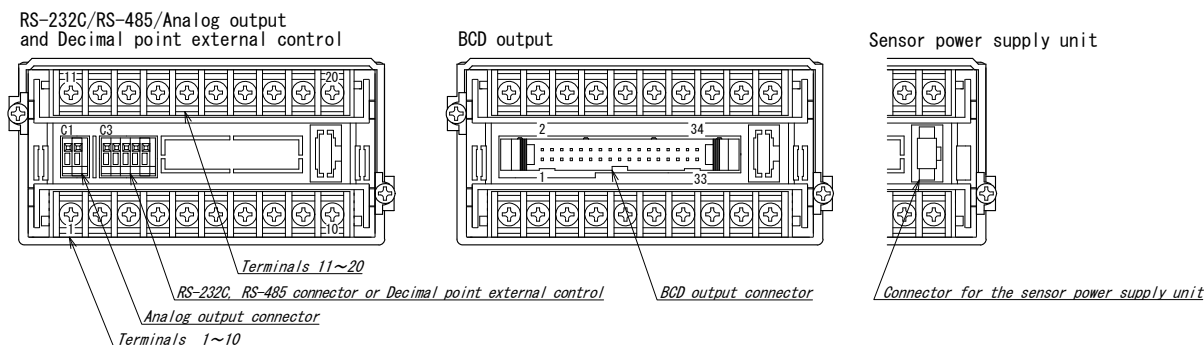

## 5. Connections

### 5.1 Terminals and Connections

**⚠ WARNING**

- To avoid an electrical shock, turn the power off when wiring.
- Do not wire with moistened hands. Locate away from the wet place.
- Do not touch terminals when turning the power on.

**⚠ CAUTION**

- Power supply and load should be within the suitable range.
- Power supply should be rapidly reach the rated power within few seconds.
- When the power is turned OFF and ON again soon after, provide the downtime of 10 seconds or more.
- Do not miswiring.

• Note for wiring

- (1) Lay the input cable and the power cable separately.  
Otherwise indication may be fluctuated.
- (2) Provide appropriate noise protection when operating solenoid or large relay by using the relay output.  
Sealed case or power line filter or isolated transformer may be effective.
- (3) COM, HOLD, ZS, MR and ALRESET terminals are not insulated.  
Terminals shall be wired to photo coupler, relay, switch, and so on.  
Each meter shall be insulated when plural mounting.

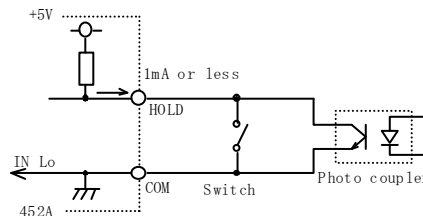

■ Terminals

Terminals are not insulated from the input.

Active "L"  $I_{IL} \leq -1mA$ , "L"=0~1.5V, "H"=3.5~5V

- Hold : Hold display, data output, current value, peak memory, bottom memory, display amplitude and comparator output.  
Hold the data when the hold input is active.
- ZS : Offset the electrical input value at ZERO. The ZS LED is lit when the Zero set function is effective.
- MR : Rest peak memory, bottom memory, and jump width.  
Minimum pulse width: 140ms
- ALRESET : Release (OFF) alarm outputs and GO outputs.  
Minimum pulse width: 10ms

● Terminals

Relay output

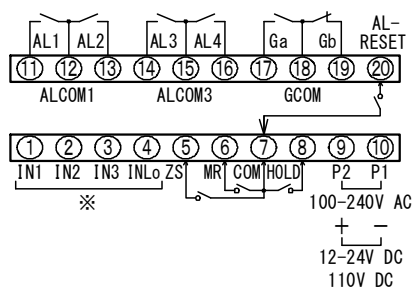

Open collector output

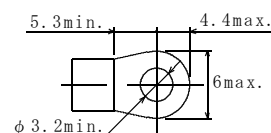
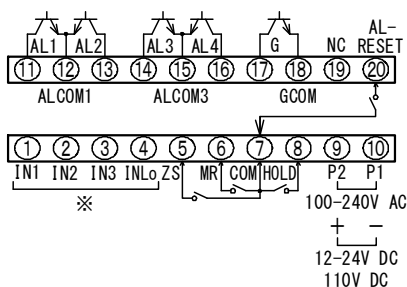

Terminal screws : M3  
Fastening torque : 0.46~0.62N·m  
Crimped terminal : Refer to the figure at the above.

※Refer to terminal number on page 12.

Please select the input range refer to function explanation parameter 04 on page 7.

**⚠ CAUTION**

**Make a connection between only one terminal among the terminal No.1 to 3, and the terminal No.4, depending upon the type and range of measuring input.**

**More than one terminal of the terminal No.1 to 3 must not be used at a time.**

**Improper connection of the terminal may cause damage, breakdown, malfunction or other trouble of this product.**

● Analog output connector

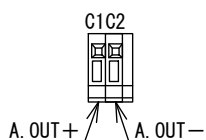

● BCD connector

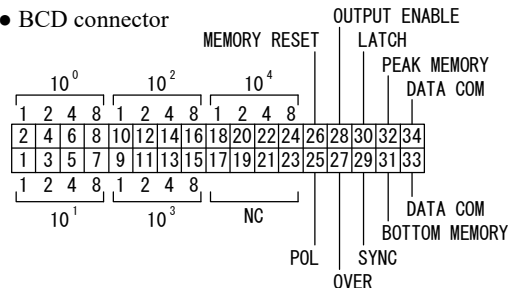

Suitable connector  
XG4M-3430-T:OMRON Corp.  
with 2m cable

● RS-232C output connector

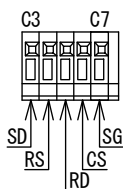

● RS-485 output connector

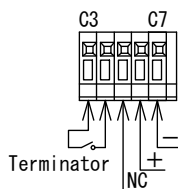

● Decimal point external control connector

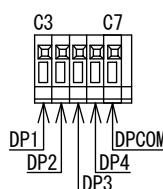

Recommended wire ( Solid wire : AWG28 to 22  
Twisted wire : AWG28 to 22  
O.D. 0.125 min.

Strip-off length: 9 to 10mm

● Sensor power supply terminals

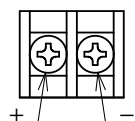

Terminal screws : M3  
Fastening torque : 0.46~0.62N·m  
Crimped terminal : Refer to the figure at the right.

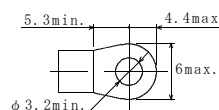

### 5.2 Attaching and detaching of terminal block cover

● Assemble procedures

- (1) Direct the claws of the cover to the terminal blocks. "a"
- (2) Insert the claw on either side of the cover as the figure shows. "b"  
Insert the claw on another side until it clicks.  
Thus, the attaching is completed.

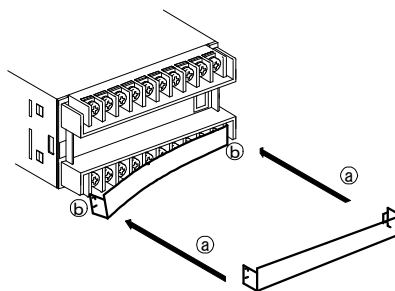

● Disassemble procedures

- (1) Pressing the surface on one side of the cover, slightly slide it downwards. "c"
- (2) Insert a small screwdriver into the gap made between the side wall of the terminal blocks and the claw of the cover, and stretch it outward. "d"
- (3) Move whole the cover downwards, then the claw on another side is departed from the terminal blocks. "e"

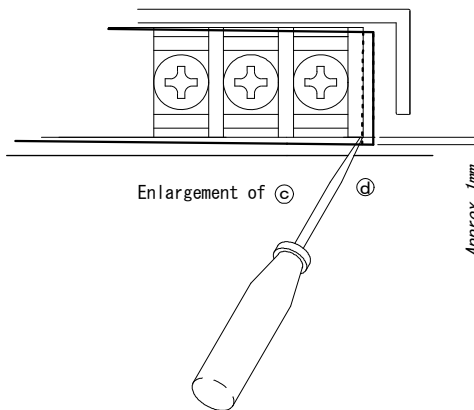
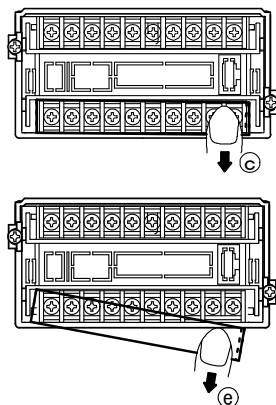

### 5.3 How to mount the sensor power supply unit

● Assemble procedures

- (1) Make sure that there is no miswiring to the case.
- (2) Connect the connector of the sensor power supply unit to the case. "a"
- (3) Hook up the unit to the case. "b"

**⚠ CAUTION**

● Make sure that the supply voltage and serial number matches to that of the case. Wrong voltage or miss-combination will damage the unit.

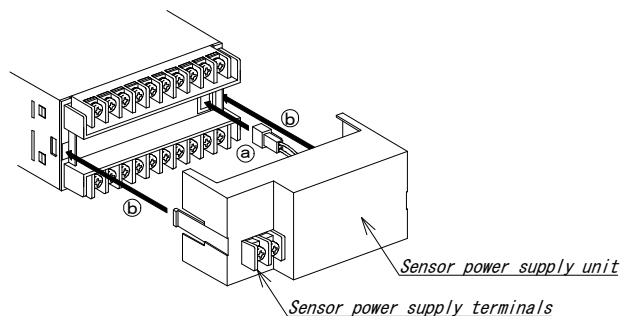

● Disassemble procedures

- (1) Insert the slotted blade driver to the "c" position on the drawing, and turn it outward as "d".
- (2) After hooking off the hook of the sensor power supply unit, pull it out as "e".
- (3) Disconnect the connector.

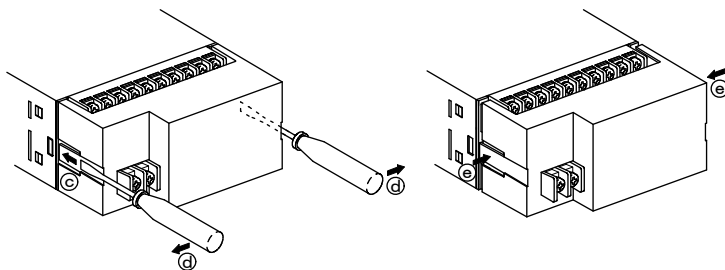

● Example of connection of two wire transmitter

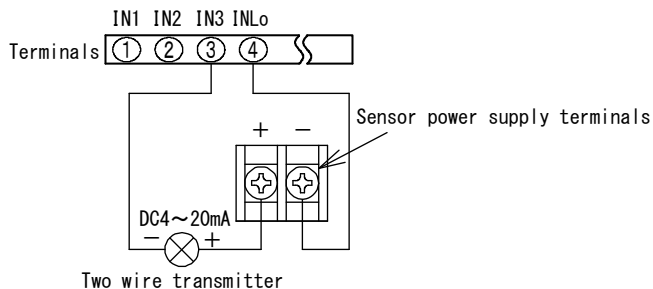

## 6. Function

### 6.1 Parameter list

#### ● Display function

No.	Function	Display	Contents	Default
01	Scaling offset	OFFS	-99999 to +99999	00000
02	Scaling full scale	FULL	-99999 to +99999	19999
03	Decimal point	dP.	0, 0.0, 0.00, 0.000, 0.0000	0
04	Input range Changeable -04, -14 and -49	CH	CH1 to CH3 Others are indicated by Err1 message	CH1 (-49:CH3)
05	Display cycle	RAFE	67ms, 400ms, 1s, 2s, 4s, 5s	67ms (SP1)
06	Average calculation	ARUE	OFF, ON, 2, 4, 8, 16, and 32 times	OFF
07	Offset fixing	ALOCK	ON, OFF	OFF
08	Zero fixing of 10 <sup>0</sup> digit	ELOCK	ON, OFF	OFF
09	Cut-off	CUT.	00.00 to 19.99%	00.00
10	Zero set	SEF.	ON, OFF	OFF
11	PV Display color	Color.	RR, RG, GR, GG	RG*
12	SV1 Display	Sub. 1	OFF, AL1 to 4, RM, PM, BM, PB	AL3
13	SV2 Display	Sub. 2	OFF, AL1 to 4, RM, PM, BM, PB	AL2
14	Display shutoff timer (Setting of light out time for PV, SV1 and SV2)	Turn	ON, OFF, 0 to 99 min.	0, 0, 0, 01 (0: OFF)

\*RG  

 Green when all AL turn OFF.  
 Red when any AL from 1 to 4 ON.

Use an attached display label when changing the display.

#### ● Alarm Output

No.	Function	Display	Contents	Default
40	Power On delay	PdLY	2 to 99 seconds	02
41	Comparison data	CSEL	RM, PM, BM, PB	RM (current value)
42	AL1 Comparison value	AL. 1	-99999 to +99999	2000
43	AL2 Comparison value	AL. 2	-99999 to +99999	3000
44	AL3 Comparison value	AL. 3	-99999 to +99999	7000
45	AL4 Comparison value	AL. 4	-99999 to +99999	8000
46	AL1 Hysteresis	HYS. 1	1 to 9999	0001
47	AL2 Hysteresis	HYS. 2	1 to 9999	0001
48	AL3 Hysteresis	HYS. 3	1 to 9999	0001
49	AL4 Hysteresis	HYS. 4	1 to 9999	0001
50	AL1 Comparison method	FORN1	OFF, HI, LO	OFF
51	AL2 Comparison method	FORN2	OFF, HI, LO	LO
52	AL3 Comparison method	FORN3	OFF, HI, LO	HI
53	AL4 Comparison method	FORN4	OFF, HI, LO	OFF
54	Output Delay	odLY	0 to 99 seconds	00
55	Comparison conditions	EQUAL	GO, NG	NG
56	Zone setting	ZONE	ON, OFF	OFF

#### ● BCD output

No.	Function	Display	Contents	Default
70	BCD output sampling	bcdSP.	SAMP, DISP (sampling cycle or display cycle)	DISP (Display cycle)

#### ● Analog output

No.	Function	Display	Contents	Default
75	Output switching	ASEL	RM, PM, BM, PB	RM (current value)
76	Min. value	ANIn	-09: 0 to 9.9 V -29: 0 to 19.9mA	-09: 01.0 V -29: 04.0 mA
77	Max. value	ANrA	-09: 0.1 to 10.0 V -29: 0.1 to 20.0mA	-09: 05.0 V -29: 20.0 mA
78	Offset	OFFS	-99999 to +99999	00000
79	Full scale	RFULL	-99999 to +99999	19999

NOTE: After changing parameter 76 and/or 77, analog output data at the calibration mode resets to default value.

#### ● RS-232C / RS-485

No.	Function	Display	Contents	Default
80	Baud rate	BRUD	4800, 9600, 19200, 38400 bps	9600 bps
81	Data length	LEnGF.	8 bit, 7 bit	8 bit
82	Parity	PRrIF.	None, Odd, Even	None
83	Stop bit	SrOP.	2 bit, 1 bit	1 bit
84	BCC switching	bCC.	ON, OFF	OFF
85	Unit number	rSnO.	0 to 99	00

#### ● My setting mode

Registration No.	Code No.	Function
1	42	AL1
2	43	AL2
3	44	AL3
4	45	AL4
5	01	Offset
6	02	Full scale
7	03	Decimal point
8	00	NC

#### ● My setting mode

No.	Function	Display	Contents	Default
99	Code registration	nY	00 to 98 (00 for non-registration)	

### 6.2 Explanation of function

● Display function

- Parameter 01 : Select the scaled offset display.
- Parameter 02 : Select the scaled full scale display.
- Parameter 03 : Select the decimal point position.
- Parameter 04 : Select the input range (for -04, -14, and -49 only)

Setting	Input			Terminal
	-04		-49	
CH1 (IN1)	±1.9999 V	①-④	1 to 5 V	①-④
CH2 (IN2)	±19.999 V	②-④	0 to 5 V	②-④
CH3 (IN3)	±399.9 V	③-④	4 to 20 mA	③-④

- Parameter 05 : Select the display rate.  
SP1:67ms、SP2:400ms、SP3:1s、SP4:2s、SP5:4s、SP6:5s (Becomes 67ms at the moving average.)
- Parameter 06 : Select the numbers of average calculation.  
OFF: No average calculation  
ON: Sectional average  
2, 4, 8, 16, 32 : Numbers of data of moving average
- Parameter 07 : Fix the display equivalent to 0% input.  
Display can be fixed to the offset value when the input value is lower than the offset value.
- Parameter 08 : Fix the display of 10<sup>0</sup> digit to 0.
- Parameter 09 : Cut an unstable zone around 0%.  
The cut area becomes offset value.
- Parameter 10 : Offset the initial input value to 0%.
- Parameter 11 : Select the PV display color.
- Parameter 12 : Select any SV1 display from setting value, current value, peak memory, bottom memory, display amplitude, and shut-off .
- Parameter 13 : Select any SV2 display from setting value, current value, peak memory, bottom memory, display amplitude, and shut-off .
- Parameter 14 : Select the shut-off time of the display after the switch operation.

● Comparison output

- Parameter 40 : Select the stand-by time for AL 1 to 4 and GO after supplying the power.
- Parameter 41 : Select any comparison data from setting value, current value, peak memory, bottom memory, display amplitude, and shut-off .
- Parameter 42 - 45 : Select the comparison data of the AL1, AL2, AL3, and AL4.
- Parameter 46 - 49 : Select hysteresis of the AL1, AL2, AL3, and AL4. When the zone is set, it is invalid.
- Parameter 50 - 53 : Select any comparison method of the AL1, AL2, AL3, and AL4 from HI, LO to OFF.
- Parameter 54 : Select the ON delay time for AL 1 to AL 4.
- Parameter 55 : Select the comparison condition for AL 1 to AL 4 whether equal NG or equal GO.

Equal NG	Equal GO
Display value ≥ Max. setting value·······HI	Display value > Max. setting value·······HI
Min. setting value < Display value < Max. setting value···GO	Min. setting value ≤ Display value ≤ Max. setting value···GO
Display value ≤ Min. setting value·······LO	Display value < Min. setting value·······LO

- Parameter 56 : Select the judgment of the comparison output whether standard or zone.

○ Judgment example

Standard: There is no limitation, large and small, for AL1, AL2, AL3 and AL4.

- AL1 (LO) : 2000
- AL2 (LO) : 3000
- AL3 (HI) : 7000
- AL4 (HI) : 8000

Zone: AL1 < AL2 < AL3 < AL4.

- AL1 (LO) : 2000
- AL2 (LO) : 3000
- AL3 (HI) : 7000
- AL4 (HI) : 8000

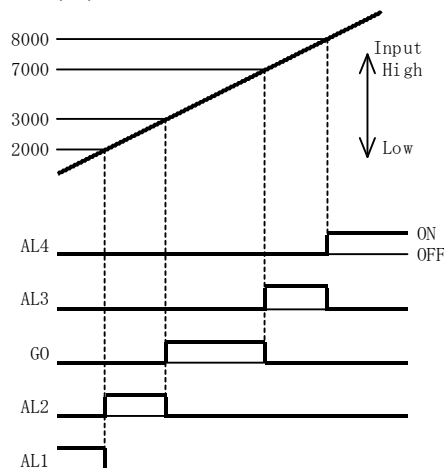
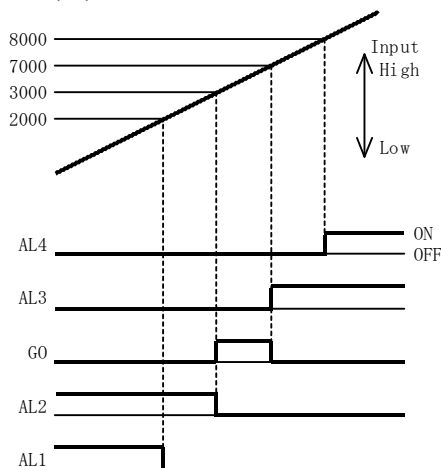

- BCD output
  - Parameter 70 : Select the BCD data, whether display cycle or sampling rate.  
Disable P-06 and -08 at the sampling rate.
  
- Analog output
  - Parameter 75 : Switch the analog output.
  - Parameter 76 : Set the output value at the 0% input.
  - Parameter 77 : Set the output value at the 100% input.
  - Parameter 78 : Set the display value at the 0% input.
  - Parameter 79 : Set the display value at the 100% input.
  
- RS-232C / RS-485
  - Parameter 80 : Select the Baud rate
  - Parameter 81 : Select the Data length.
  - Parameter 82 : Select the Parity.
  - Parameter 83 : Select the Stop bit.
  - Parameter 84 : Disable / Enable the BCC.
  - Parameter 85 : Select the Unit number.
  
- My setting mode
  - Parameter 99 : Register well-used 8 code numbers in the setting mode.



### 7. Parameter Setting

#### 7.1 How to change the comparison setting value

During the measuring mode, the comparison value of the SV1 and SV2 is changeable by pushing **COMP** key.  
 Setting example: Changes AL3 to 100.20 and AL2 to -11.00 when the comparison setting is AL3 and AL2 for the SV1 and SV2.

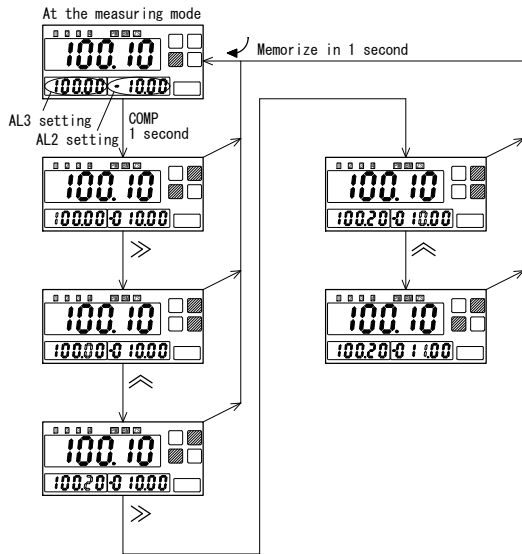

※This function is only available when SV1 and SV2 selecting to comparison setting value.

#### 7.2 PV Display switching

During the measuring mode, the display switches from current value to peak memory, bottom memory, display amplitude, and current value, by pushing **P·B** key.

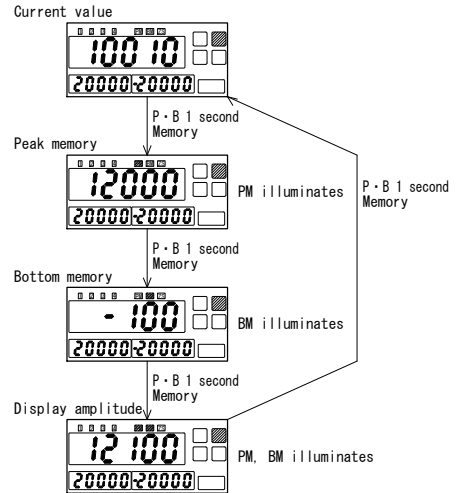

※During If keep the P·B key pushing more than 3 seconds, memory will be reset after switching the display.

#### 7.3 Parameter setting mode

During the measuring mode, the display shows “Cod00” and switches to the parameter setting mode, by pushing the **MODE** key.

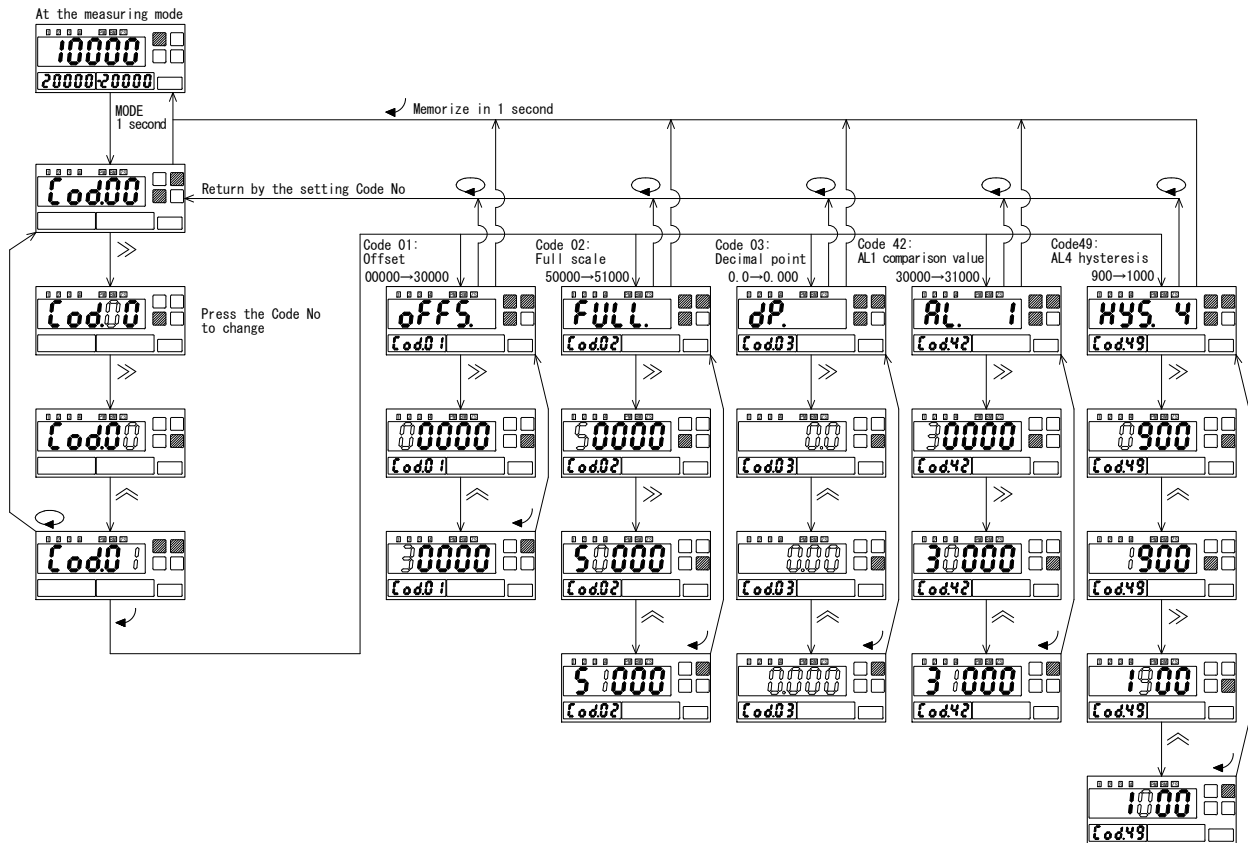

### 7.4 My setting mode

For your convenience, register well-used 8 code numbers in the setting mode.  
 During the measuring mode, the display switches the My setting mode by pushing **My** key.  
 The setting can be simplified by registering only the necessary function.

• How to register codes

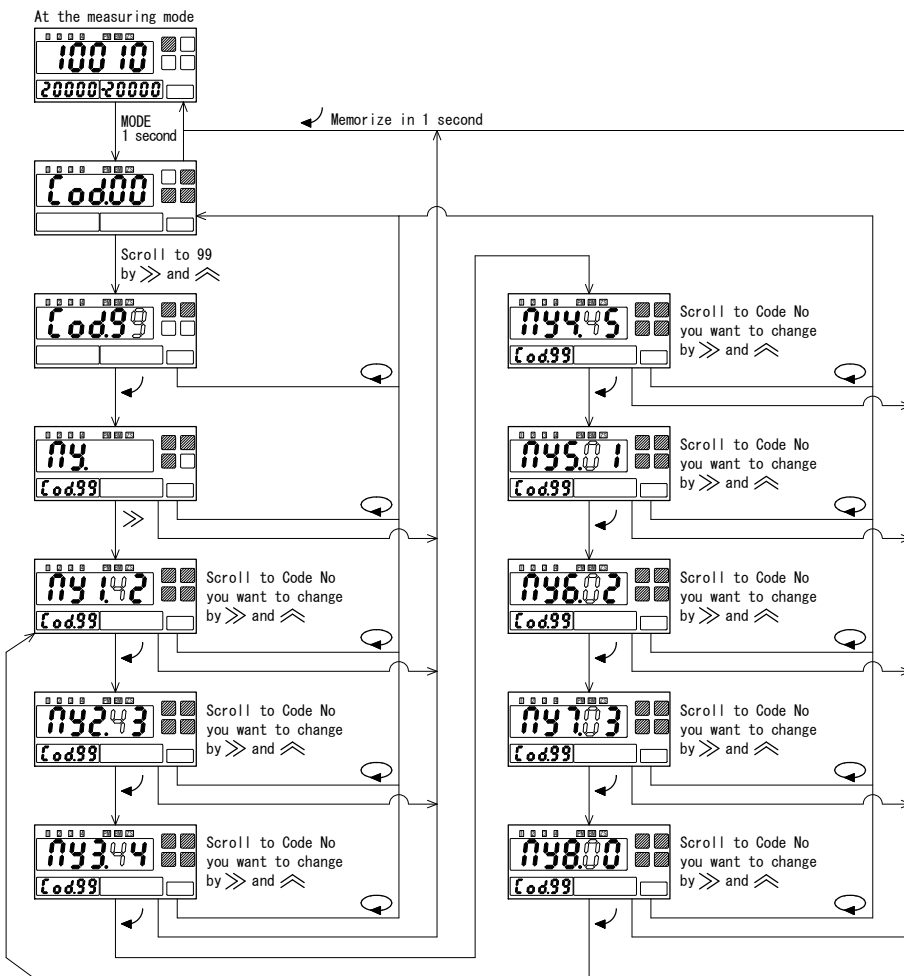

• How to change setting value

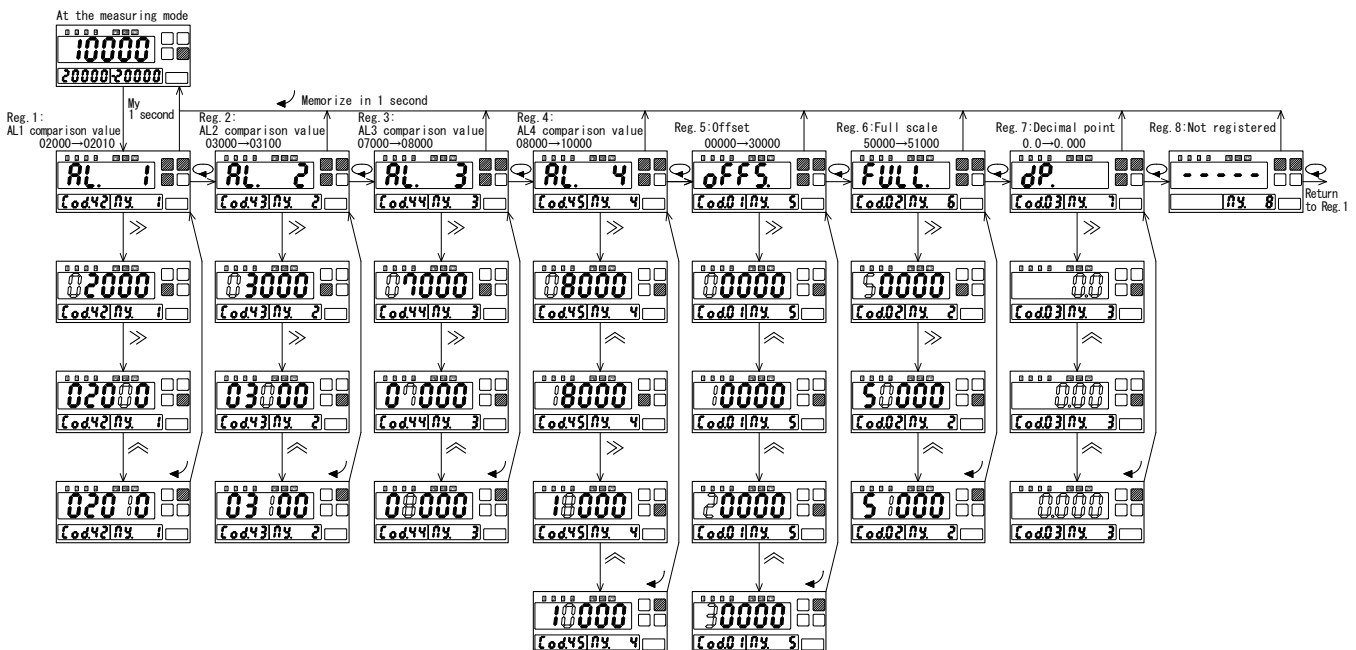

### 7.5 Calibration mode

This mode is ideal for fine calibration of the display and the optional analog output.  
 During the measuring mode, the display shows "Rd." and switches the Calibration mode by pushing **MODE** key.

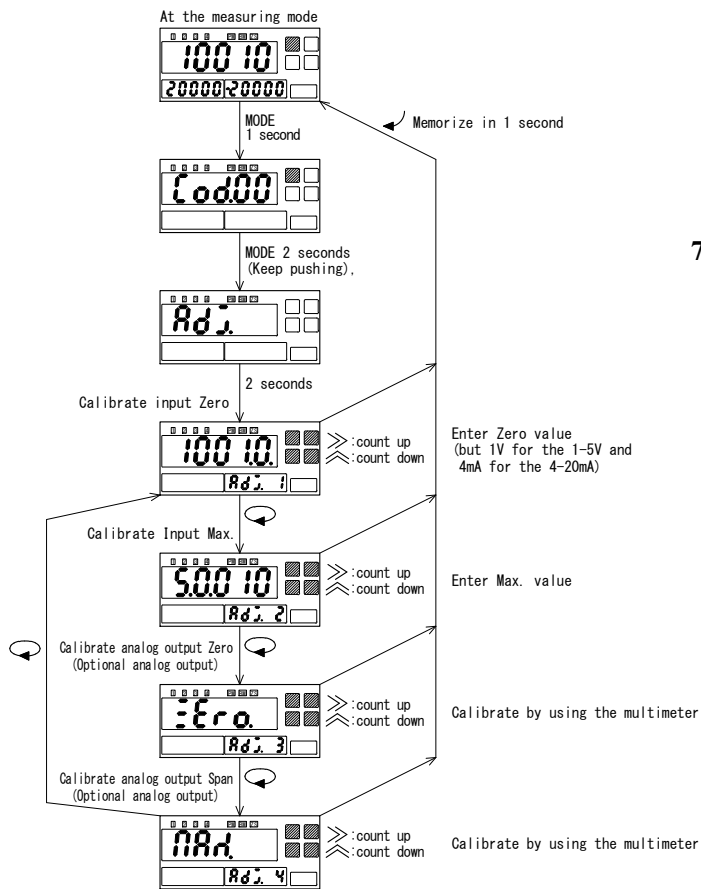

### 7.6 Reset to Default value

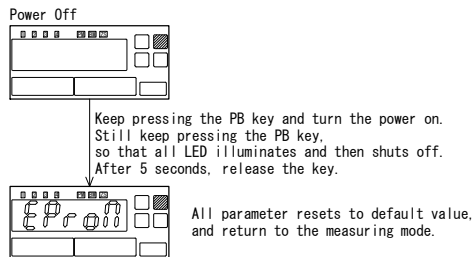

### 7.7 Error message

Display	Cause of trouble	Countermeasure
Err 1	Entered Code No. is not applicable.	Enter correct Code No.
Err 2	Entered value is out of range.	Enter correct value

※ During the parameter setting mode and the My setting mode, return automatically to the measuring mode if you do not touch the switch more than 5 minutes. Changed value does not memorize in this case.

### 7.8 Numeric and Character Indications



### 8. External Dimensions

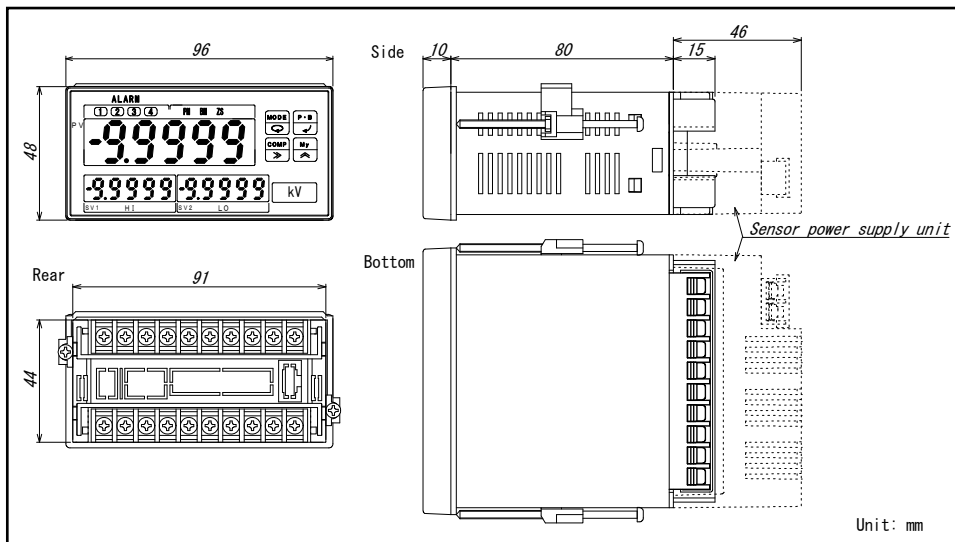

## 9. Model Numbering

452A-(1)-(2)-(3)-(4)-(5)-(6)

### [1] Measuring Input

Model	Measuring Range	Input Resistance	Error *1	Overload	Terminals
452A-01	±19.999mV	5MΩ	±(0.05% of rdg + 5 digits)	DC±50V	1-4
452A-V1	±100.00mV	5MΩ	±(0.05% of rdg + 5 digits)	DC±50V	1-4
452A-02	±199.99mV	120kΩ	±(0.05% of rdg + 3 digits)	DC±50V	1-4
452A-04	±1.9999V	1MΩ	±(0.1% of rdg + 1 digits)	DC±250V	1-4
	±19.999V	10MΩ	±(0.1% of rdg + 1 digits)	DC±250V	2-4
	±399.9V	10MΩ	±(0.1% of rdg + 3 digits)	DC±750V	3-4
452A-06	±699.9V	10MΩ	±(0.1% of rdg + 3 digits)	DC±750V	3-4
452A-11	±19.999μA	10kΩ	±(0.05% of rdg + 3 digits)	DC±2mA	1-4
452A-12	±199.99μA	1kΩ	±(0.05% of rdg + 3 digits)	DC±20mA	1-4
452A-14	±1.9999mA	100Ω	±(0.1% of rdg + 1 digits)	DC±50mA	1-4
	±19.999mA	11Ω	±(0.1% of rdg + 1 digits)	DC±150mA	2-4
	±199.99mA	1Ω	±(0.1% of rdg + 1 digits)	DC±500mA	3-4
452A-49	DC1-5V	1MΩ	±(0.1% of rdg + 1 digits)	DC±250V	1-4
	DC0-5V	1MΩ	±(0.1% of rdg + 1 digits)	DC±250V	2-4
	DC4-20mA	12.4Ω	±(0.1% of rdg + 1 digits)	DC±150mA	3-4
452A-49R	DC4-20mA	250Ω	±(0.1% of rdg + 3 digits)	DC±40mA	1-4

\*1 Error (23°C±5°C, 45~75%RH)

+□digit is defined within the resolution of 1/20000.

\*2 Temperature coefficient (0 to 50°C):

452A-01, -V1 .... ±100ppm/°C

452A-02,-04 -06,-11,-12,-13,-14 ... ±160ppm/°C

452A-49, -49R .... ±150ppm/°C

### [2] Power Supply Voltage

Code	Power Source Voltage
A	AC100 to 240V
B	DC 12 to 24V
C	DC110V

### [3] Sensor power supply unit

Code	Power Source Voltage	Output Current
Null	Not provided	
2T	DC +5V ±10%	100mA
3T	DC +12V ±5%	150mA (100mA for the DC12 to 24V power supply)
5T	DC +24V ±5%	100mA (50mA for the DC12 to 24V power supply)

### [4] Data Output 1

Code	Specifications	Impedance	Max. Load
Null	No output		
09	Analog voltage (positive input side outputs) DC 0-10V (Available scaling, Default: 1-5V)	Max. 0.1Ω	Min. 100Ω at DC 0-1V Min. 1kΩ at DC 0-10V Min. 500Ω at DC 1-5V
29	Analog current (positive input side outputs) DC 0-20mA (Available scaling, Default: 4-20mA)	Min. 5MΩ	Max. 2.4kΩ at DC 0-5mA Max. 600Ω at DC 0-20mA Max. 600Ω at DC 4-20mA
BP	BCD output (TTL level positive logic)		
BN	BCD output (TTL level negative logic)		
DP	BCD output (transistor output, source type)		
DN	BCD output (transistor output, sink type)		
E0	RS-232C		
E1	RS-485		
EC	Decimal point external control		

### [5] Data Output 2 (Available -09 and -29 of Data output 1 only)

Code	Specifications
Blank	No output
E0	RS-232C
E1	RS-485
EC	Decimal point external control

### [6] Comparison output

Code	Specifications
Blank	Relay output
TN	Open collector output (NPN)

#### Contact Information

Name : Tsuruga Electric Corporation  
Address : 1-3-23 Minami-Sumiyoshi, Sumiyoshi-ku, Osaka-shi  
558-0041 Japan

# Quick Manual

## Digital Panel Meter, Model 451A / Meter Relay, Model 452A BCD Output

I-01595

### 1. Data Output Code

Code	Specifications
BP	BCD output (TTL level positive logic)
BN	BCD output (TTL level negative logic)
DP	BCD output (transistor output, source type)
DN	BCD output (transistor output, sink type)

### 2. Connector and Connections

#### ⚠ WARNING

- To avoid an electrical shock, turn the power off when wiring.
- Do not wire with moistened hands. Locate away from the wet place.
- Do not touch terminals when turning the power on.

#### ⚠ CAUTION

- Do not miswiring. Otherwise, the meter may be broken.

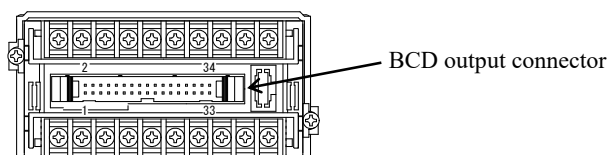

#### 2.1 Connections

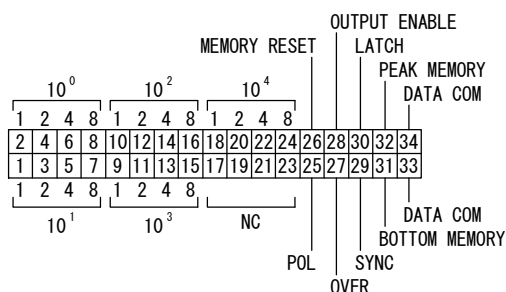

Suitable connector (attached)  
XG4M-3430-T:OMRON Corp.  
with 2m cable

#### 2.2 TTL output

- Input / Output rating

	Signal	Type -BP	Type -BN	Rating
Output	$\times 10^0$ to $\times 10^4$	Positive logic	Negative logic	TTL level Fo=2 CMOS compatible
	POL	+ = H, - = L	+ = L, - = H	
	OVER	H at over	L at over	
	SYNC	L pulse of 10ms		
Input	LATCH	Hold at L (short-circuit)		$I_{IL} \leq -1\text{mA}$ L = 0 to 1.5V H = 3.5 to 5.0V
	ENABLE	Enable at H (open), Disable at L (short-circuit)		
	MEMORY RESET	Reset at L (short-circuit)		
	PEAK/BOTTOM MEMORY	Refer to each item		

- Measuring data output ( $\times 10^0$  to  $\times 10^4$ )

Parallel BCD (1-2-4-8) code, latch output. The output is Tri-state type, so a connection to the data bus is easy.

- Polarity Output (POL)

Outputs data polarity to No.25 pin.

- Over Output (OVER)

Outputs over display to No. 27 pin.

When exceeded 130% display, outputs both 130% display and over data. When exceeded 99999, outputs 0 data and over data.

● Synchronization (SYNC)

Outputs L pulse of 10ms, which synchronizes display cycle, to No. 29 pin. Readouts the data on the rising edge of this SYNC. Wired OR connection is possible when connecting several data bus.

● Data enable input (OUTPUT ENABLE)

Outputs datum, includes POL and OVER, when opening (setting to H) No. 28 pin. When short-circuiting (setting to L) with DATA COM between No. 33 and No.34 pin, DATA, includes POL and OVER, changes to high impedance condition. In this state, SYNC output is prohibited and the connection to the data bus is easy.

● Latch input (LATCH)

Latches BCD data by short-circuiting between No. 30 and DATA COM (No. 33 and No. 34 pins) or setting to L. Display does not latch.

● PEAK MEMORY and BOTTOM MEMORY

Switches output data to current value, peak memory value, bottom memory value, and amplitude value, by the operation of No. 31 to No. 34 pins.

Signal	Current value	Peak memory value	Bottom memory value	Amplitude value
No. 32 pin (Peak memory)	Open H	Short-circuit L	Open H	Short-circuit L
No. 31 pin (Bottom memory)	Open H	Open H	Short-circuit L	Short-circuit L

● MEMORY RESET

Switches peak memory and bottom memory to current value by short-circuiting between No. 26 pin and DATA COM (No. 33 and No. 34 pins).

● Data common (DATA COM)

No. 33 and No. 34 pins are common for measuring data output, POL, OVER, SNYC, LATCH, OUTPUT ENABLE, PEAK MEMORY, BOTTOM MEMORY, and MEMORY RESET.

● NC

Do not use non-occupied NC pin for junction purpose.

※Do not apply 5V DC or more due to uniform to TTL level of data output and control signal. Arrange the wiring of data output and control input/output lines apart from the power source line, relays or magnet switches, etc. of big capacity, as well as the input line.

2.3 Transistor output

Wired OR connection is possible for the measuring data, including POL and OVER, and SYNC when connecting several BCD outputs to a PC.

● Input / Output rating

	Signal	Item	Type -DP	Type -DN
Output	$\times 10^0$ to $\times 10^4$	Output	Source type	Sink type
	POL OVER SYNC	Output capacity	DC30V 30mA Max., Saturation Voltage: 1.6V Max.	
Input	LATCH ENABLE MEMORY RESET PEAK MEMORY BOTTOM MEMORY	Signal level	Input current: Max. 1mA OFF (H) = 3.5 to 5.0V, ON (L) = 0 to 1.5V	

● Measuring data output ( $\times 10^0$  to  $\times 10^4$ )

Parallel BCD code (1-2-4-8), Latch output.  
Transistor turns on (ON) at 1 measuring data.  
Transistor turns off (OFF) at 0 measuring data.

● Polarity Output (POL)

Outputs data polarity to No.25 pin.  
Transistor turns on (ON) at (+) display value.  
Transistor turns off (OFF) at (-) display value.

● Over Output (OVER)

Outputs over display to No. 27 pin.  
Transistor turns on (ON) at over display.  
When exceeded 130% display, outputs both 130% display and over data. When exceeded 99999, outputs 0 data and over data.

● Synchronization (SYNC)

Outputs L pulse of 10ms, which synchronizes display cycle, to No. 29 pin.  
Readouts the data on the rising edge of this SYNC.

● Data enable input (OUTPUT ENABLE)

Outputs datum, includes POL and OVER, when opening (setting to H) No. 28 pin.  
When short-circuiting (ON) with DATA COM between No. 33 and No.34 pin, DATA, includes POL and OVER, changes to OFF condition. In this state, SYNC output is prohibited and the connection to the data bus is easy.

● Latch input (LATCH)

Latches BCD data by short-circuiting between No. 30 and DATA COM (No. 33 and No. 34 pins). Display does not latch.

● PEAK MEMORY and BOTTOM MEMORY

Switches output data to current value, peak memory value, bottom memory value, and amplitude value, by the operation of No. 31 to No. 34 pins.

Signal	Current value	Peak memory value	Bottom memory value	Amplitude value
No. 32 pin (Peak memory)	Open	Short-circuit	Open	Short-circuit
No. 31 pin (Bottom memory)	Open	Open	Short-circuit	Short-circuit

● MEMORY RESET

Switches peak memory and bottom memory to current value by short-circuiting between No. 26 pin and DATA COM (No. 33 and No. 34 pins).

● Data common (DATA COM)

No. 33 and No. 34 pins are common for measuring data output, POL, OVER, SNYC, LATCH, OUTPUT ENABLE, PEAK MEMORY, BOTTOM MEMORY, and MEMORY RESET.

● NC

Do not use non-occupied NC pin for junction purpose.

※Arrange the wiring of data output and control input/output lines apart from the power source line, relays or magnet switches, etc. of big capacity, as well as the input line.

3.Example of connection

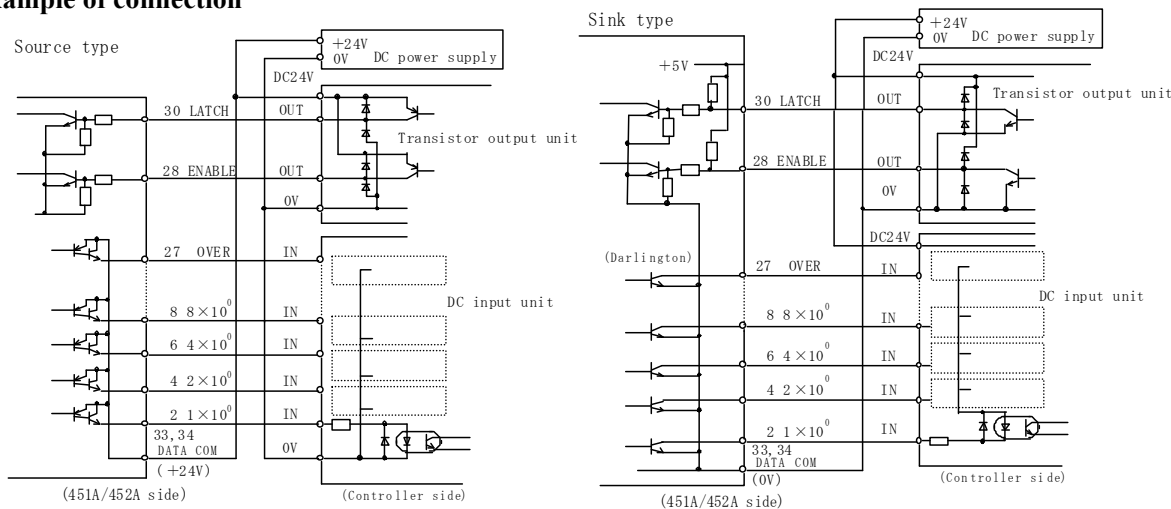

4.Timing chart

●BCD data and LATCH

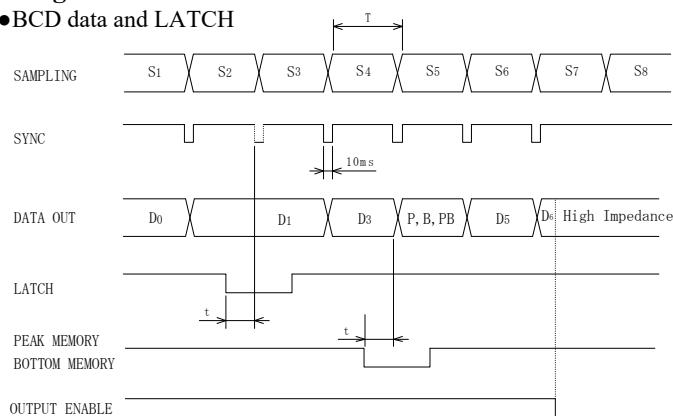

●BCD data and HOLD

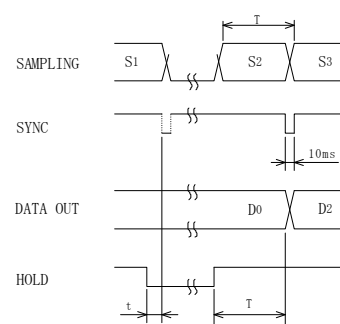

t: internal operation time approx. 15ms  
T: display cycle or sampling cycle (67ms)

PorB: Peak memory value, Bottom memory value or amplitude value

t: internal operation time approx. 15ms

T: display cycle or sampling cycle (67ms)

**CAUTION**

Regarding the BCD output when supplying the power

1. Supply power shall rise to the rated voltage within 1 second after activation.
2. The model 451A/452A may output unstable data due to initialization within 3 seconds of starting. Start data acquisition 3 seconds later after reaching the rated voltage.

## 5. Switch BCD output cycle

BCD output cycle is possible to choose whether display cycle or sampling cycle (67ms).  
Refer to our Quick manual, I-01593 and I-01594, for detailed setting procedures.

Contact Information
Name : Tsuruga Electric Corporation
Address : 1-3-23 Minami-Sumiyoshi, Sumiyoshi-ku, Osaka-shi 558-0041 Japan



# Quick Manual

## Digital Panel Meter, Model 451A / Meter Relay, Model 452A Analog Output

I-01596

### 1. Data Output Code

Code	Specifications	Output Impedance	Max. Load
09	Analog voltage (positive input side outputs) * DC 0-10V (Available scaling, Default: 1-5V)	Max. 0.1 Ω	Min. 100 Ω at DC 0-1V Min. 1k Ω at DC 0-10V Min. 500 Ω at DC 1-5V
29	Analog current (positive input side outputs) * DC 0-20mA (Available scaling, Default: 4-20mA)	Min. 5M Ω	Max. 2.4k Ω at DC 0-5mA Max. 600 Ω at DC 0-20mA Max. 600 Ω at DC 4-20mA

\* Outputs the positive input side

Example: Input signal is  $\pm 1.9999V$ , and analog output is 0-20mA DC.

Input	Output
0V	0mA
1.9999V	20mA

### 2. Connector and Connections

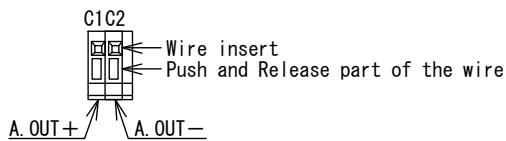
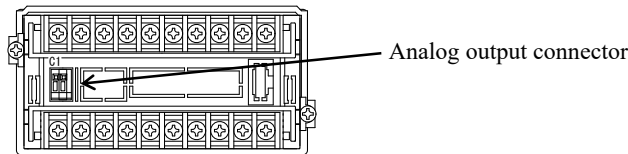

Recommended wire ( Solid wire : AWG28 to 22  
Twisted wire : AWG28 to 22  
O.D. 0.125 min.

Strip-off length: 9 to 10mm

Outputs voltage and current is in proportional to input signal.

#### ⚠ CAUTION

●Do not apply voltage to the analog output connector. Otherwise, the meter may be broken.

### 3. Functions

Refer to our Quick manual, I-01593 and I-01594, for detailed setting procedures.

- Output switching : (Parameter 75) Switch the analog output.  
Select any data from current value, peak memory, bottom memory, and display amplitude.
- Min. / Max. Value : (Parameter 76 and 77) Set the output value at the 0% input and 100% input.  
Example 1: Switch the output of the -09 from 0-10V to 0-2V / 1-5V.

	Parameter 76	Parameter 77
0-10V	00.0V	10.0V
0-2V	00.0V	02.0V
1-5V	01.0V	05.0V

Example 2: Switch the output of the -29 from 0-20mA to 0-10mA / 4-20mA.

	Parameter 76	Parameter 77
0-20mA	00.0mA	20.0mA
0-10mA	00.0mA	10.0mA
4-20mA	04.0mA	20.0mA

- Offset / Full scale : (Parameter 78 and 79) Set the display value at the 0% input and 100% input.  
Example 1: Output 4-20mA in proportional to 10000 - 50000 display.  
Example 2: Output 1-5V in proportional to -10000 - (+) 10000 display.

	Data output code	Parameter			
		76	77	78	79
Example 1	-29	04.0mA	20.0mA	10000	50000
Example 2	-09	01.0V	05.0V	-10000	10000

The offset value may be lower or higher than the full scale value.

#### 4. Calibration

In order to maintain long term accuracy, periodical calibration at an interval of about one year is recommended.

Make a calibration in the ambient condition of  $23^{\circ}\text{C} \pm 5^{\circ}\text{C}$ , 75%RH or less. Refer to our Quick manual, I-01593 and I-01594, for detailed calibration procedures.

#### 5. Specifications

The measuring input and the analog output is insulated. Outputs the positive input side.

Conversion : PWM conversion system

Allowable Error :  $\pm 0.15\%$  of Span at  $23^{\circ}\text{C} \pm 2^{\circ}\text{C}$

Temperature coefficient :  $\pm 200\text{ppm}/^{\circ}\text{C}$

Linearity : 0.1 % of Span

Resolution : 1/10000 (for 0-10V DC and 0-20mA DC output)

Output periodicity : 67ms

※ If the input signal is over full scale, output is saturated at 100%.

Example: Saturated 20mA at 4-20mA setting, and 5V at 1-5V setting.

<b>Contact Information</b>	
Name	: Tsuruga Electric Corporation
Address	: 1-3-23 Minami-Sumiyoshi, Sumiyoshi-ku, Osaka-shi 558-0041 Japan

# Quick Manual

## Digital Panel Meter, Model 451A / Meter Relay, Model 452A RS-232C / RS-485 Output

I-01597

### 1. Data Output Code

Code	Output
E0	RS-232C
E1	RS-485

### 2. Specifications

#### 2.1 Common specifications for RS-232C and RS-485

The measuring input and the RS-232C and RS-485 output is insulated.

Transmission	: Start-Stop half-duplex transmission
Transmission speed	: 4800, 9600, 19200, 38400 bps
Data length	: 7bit / 8bit
Parity	: None, Odd, Even
Stop bit	: 1bit / 2bit
Data	: In conjunction with JIS 8 units code
X parameter	: None
Error detection	: Parity (Choose BCC availability) Operation results of exclusive logic sum just after STX to ETX
Control character	: STX (02H) start of text / ETX (03H) end of text
Device No.	: 00 to 99 Set the device No. to each device, and match each command of device
Transmission character	: Max. 32
Transmission process	: Ignored

452A/451A transmits response in accordance with command frame from the upper PC.

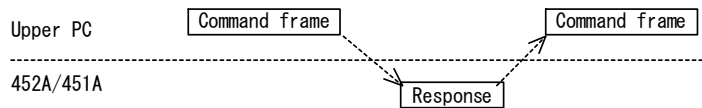

#### • RS-485

Connected device numbers	: Max. 32, including the upper PC
Line length	: Up to 500 m by using shielded twisted-pair cable, AWG28 to 22.
Terminator	: Switched by the jumper at the terminal, terminated at 200 Ω

NOTE followings for the use of multi-drop.

- Unify the transmission format.
- Do not duplicate the device number.

### 3.Connector and Connections

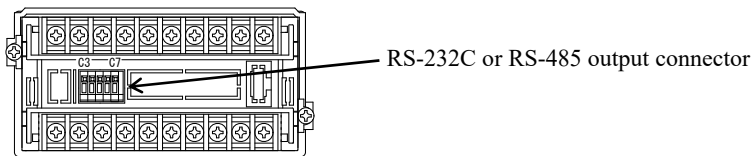

#### 3.1 RS-232C

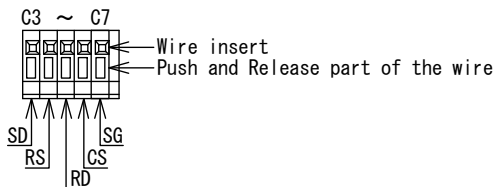

Recommended wire { Solid wire : AWG28 to 22  
Twisted wire : AWG28 to 22  
O.D. 0.125 min.

Strip-off length: 9 to 10mm

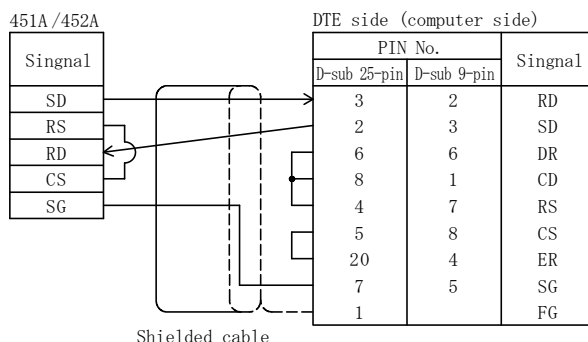

### 3.2 RS-485

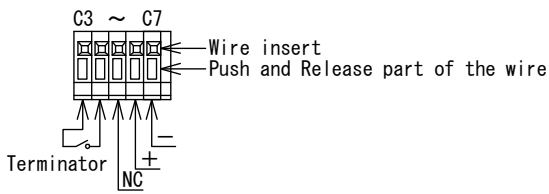

※ Recommended wire ( Solid wire : AWG28 to 22  
Twisted wire : AWG28 to 22  
O.D. 0.125 min.  
Strip-off length: 9 to 10mm

※ In case of multi-drop connection, strand twisted wire AWG28 to AWG26 and insert.

Terminator: When short-circuiting the connector, 200Ω resistor is connected in parallel to the line  
Input/Output: “+” is non-inverse output, and “-” is inverse output.

● Connection

In case of RS-485 connection, up to 32 devices, includes the upper computer, are possible to connect. Specify the end station for both ends of device on the line. Set the terminator to be short-circuited for the identification of the end station. Lead wire for short-circuit is not attached. Use the converter for another identification to set the terminator.

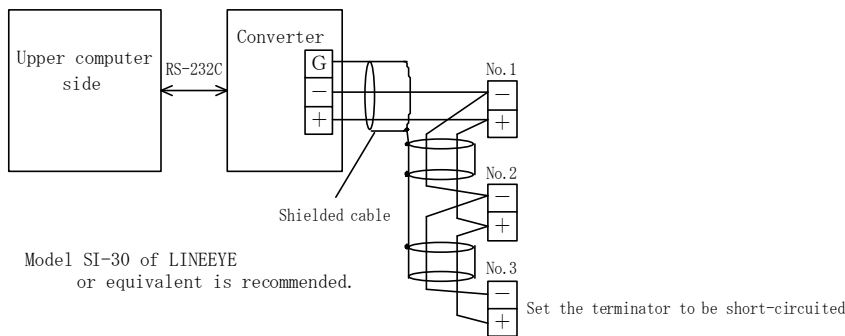

### 3.3 Communication setting

Use keys on the front panel for communication setting. Refer to I-01593 or I-01594 for key operation.

- Transmission speed, Data length, Parity, Stop bit, BCC availability
- Device number

## 4. Communication command

### 4.1 Notes for Command

- 1) BCC should be added after ETX if BCC function is available.
- 2) All frame of command  
Command: STX device No., Command or Command frame, ETX (BCC)  
Response: STX device No., End code, Response, ETX (BCC)
- 3) Character of command is effective with 4-character from the top. Ex)RLATCH → RLAT
- 4) Both figure and character is effective. Ex) WC07 0 or WC07 OFF
- 5) End code

Return the receive condition of the command frame.

End code	Contents
A (41H)	Normal end
B (42H)	During setting (communicates during setting)
C (43H)	Setting error (out of setting range or error)
D (44H)	BCC error (with BCC function)
P (50H)	Command error (impossible to analyze the received command)

Response at the command error

STX	Device No.	End code	ETX	(BCC)	
(02H)	(30H)	(30H)	(50H)	(03H)	Device No. 00

Response during setting

STX	Device No.	End code	ETX	(BCC)	
(02H)	(30H)	(30H)	(42H)	(03H)	Device No. 00

### ⚠ CAUTION

Regarding the command when supplying the power

1. Supply power shall rise to the rated voltage within 1 second after activation.
2. The model 451A/452A may not respond due to initialization or may return unstable response within 3 seconds of starting. Start communication 3 seconds later after reaching the rated voltage.

### 4.2 Command / Response

• Measuring command

- Command : DATA?, The current data, Request to judge
- Response : response to DATA?, Collect the current data, judgment
- Command : RMREad, request to the current data
- Response : response to RMREad, Collect the current data
- Command : PMREad, request to the peak memory data
- Response : response to PMREad, Collect the peak memory data
- Command : BMREad, request to the bottom memory data
- Response : response to BMREad, Collect the bottom memory data
- Command : PBREad, request to the amplitude
- Response : response to PBREad, Collect the amplitude measuring data

Data format

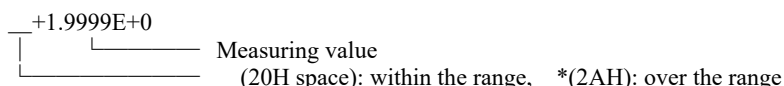

- Command : DATA?, The current data, Request to judge
- Response : response to DATA?

+1.9999 ..... 451A  
 -1.9999 AL1, AL2, ON..... 452A

Command frame

STX	Device No.	D	A	T	A	?	ETX (BCC)			Device No. 00
02H	30H	30H	44H	41H	54H	41H	3FH	03H		

Response

STX	Device No.	↓		+	1	.	9	9	9	9	E	+	0	ETX (BCC)		.....451A
02H	30H	30H	41H	20H	2BH	31H	2EH	39H	39H	39H	39H	45H	2BH	30H	03H	

Response

STX	Device No.	↓		-	1	.	9	9	9	9	E	+	0	,	0	3	ETX (BCC)		.....452A
02H	30H	30H	41H	20H	2DH	31H	2EH	39H	39H	39H	39H	45H	2BH	30H	2CH	30H	33H	03H	

- Command : PMREAD, Request to peak memory data
- Response : response to PMREAD

+9.9999

Command frame

STX	Device No.	P	M	R	E	A	D	ETX (BCC)		Device No. 00
02H	30H	30H	50H	4DH	52H	45H	41H	44H	03H	

Response

STX	Device No.	↓		+	9	.	9	9	9	9	E	+	0	ETX (BCC)		
02H	30H	30H	41H	20H	2BH	39H	2EH	39H	39H	39H	39H	45H	2BH	30H	03H	

• Readout the device information

- Command : IDNT?, Read out the device information
- Response : response to IDNT?  
 452A-04-29-E0, No.495-000 (Model No. Soft registration No. (Tsuruga))

Command frame

STX	Device No.	I	D	N	T	?	ETX (BCC)			Device No. 00
02H	30H	30H	49H	44H	4EH	54H	3FH	03H		

Response

STX	Device No.	↓	4	5	2	A	-	0	4	-	2	9	-	
02H	30H	30H	41H	34H	35H	32H	41H	2DH	30H	34H	2DH	32H	39H	2DH

Response

E	0	,	N	o	.	4	9	5	-	0	0	0	ETX (BCC)	
45H	30H	2CH	4EH	6FH	2EH	34H	39H	35H	2DH	30H	30H	30H	03H	

• Readout the judgment

- Command : ALARm, Read out the judgment
- Response : response to ALARm  
 16 (GO output)

Command frame

STX	Device No.	A	L	A	R	M	ETX (BCC)			Device No. 00
02H	30H	30H	41H	4CH	41H	52H	4DH	03H		

Response

STX	Device No.	↓	1	6	ETX (BCC)		
02H	30H	30H	41H	31H	36H	03H	

• Readout the setting data

Command : RC01, Read out the offset setting

Response : response to RC01.  
00000

Command frame

STX	Device No.	R	C	0	1	ETX (BCC)
02H	30H	30H	52H	43H	30H	31H 03H

Device No. 00

Response End code

STX	Device No.	↓	0	0	0	0	0	ETX (BCC)
02H	30H	30H	41H	30H	30H	30H	30H	03H

• Set the function command data

Command : WC01\_00000, Set the offset

Response : response to WC01\_00000.  
00000

Command frame

STX	Device No.	W	C	0	1	_	0	0	0	0	0	ETX (BCC)
02H	30H	30H	57H	43H	30H	31H	20H	30H	30H	30H	30H	03H

Device No. 00

Response End code

STX	Device No.	↓	0	0	0	0	0	ETX (BCC)
02H	30H	30H	41H	30H	30H	30H	30H	03H

• Readout the control command data

Command : RLATch, Read out the latching

Response : response to RLATch.  
0 (OFF)

Command frame

STX	Device No.	R	L	A	T	C	H	ETX (BCC)
02H	30H	30H	52H	4CH	41H	54H	43H 48H	03H

Device No. 00

Response End code

STX	Device No.	↓	0	ETX (BCC)
02H	30H	30H	41H	30H 03H

• Set the control command data

Command : WLATch\_0, Set the offset

Response : response to WLATch\_0.  
0 (OFF)

Command frame

STX	Device No.	W	L	A	T	C	H	_	0	ETX (BCC)
02H	30H	30H	57H	4CH	41H	54H	43H 48H	20H	30H	03H

Device No. 00

Response End code

STX	Device No.	↓	0	ETX (BCC)
02H	30H	30H	41H	30H 03H

• Memory control command

• Write command: Write the setting data into the EEPROM.

Command : STOR

Response : End code

Command frame

STX	Device No.	S	T	O	R	ETX (BCC)
02H	30H	30H	53H	54H	4FH	52H 03H

Device No. 00

Response End code

STX	Device No.	↓	ETX (BCC)
02H	30H	30H	41H 03H

Normal end

• Memory initialization: Setting datum resets to default, except of transmission speed, data length, parity, stop bit, BCC switch, and device No.

Command : DEFAult

Response : End code

Command frame

STX	Device No.	D	E	F	A	U	L	T	ETX (BCC)
02H	30H	30H	44H	45H	46H	41H	55H	4CH	54H 03H

Device No. 00

Response End code

STX	Device No.	↓	ETX (BCC)
02H	30H	30H	41H 03H

Normal end

4.3 Command table

● Setting command

Function	Requested command		Specified command			Applicable Model
	Command	Response	Command frame	Response	Function, range	
Scaling offset	RC01	00000	WC01_00000	00000	-99999 to 99999	Common
Scaling full scale	RC02	19999	WC02_99999	99999	-99999 to 99999	
Decimal point	RC03	0	WC03_0	0	0:0, 1:0.0, 2:0.00, 3:0.000, 4:0.0000	
Input range selection	RC04	1	WC04_1	1	1, 2, 3	
Display cycle	RC05	1	WC05_1	1	0:67ms, 1:400ms, 2:1s, 3:2s, 4:4s, 5:5s	
Average calculation (Section, Moving)	RC06	0	WC06_0	0	0:OFF, 1:ON, 2:2, 3:4, 4:8, 5:16, 6:32 times	
Offset fixing	RC07	0	WC07_0	0	1:ON, 0:OFF	
Zero fixing of 10 <sup>0</sup> digit	RC08	0	WC08_0	0	1:ON, 0:OFF	
Cut-off	RC09	00.00	WC09_10.00	10.00	0.00 to 19.99	
Zero set	RC10	0	WC10_1	1	1:ON, 0:OFF	
PV Display color	RC11	1	WC11_3	3	0:RR, 1:RG, 2:GR, 3:GG	452A
	RC11	3	WC11_3	3	0:RR, 1:RG, 2:GR, 3:GG	451A
SV1 Display	RC12	3	WC12_0	0	0:OFF, 1:AL1, 2:AL2, 3:AL3, 4:AL4, 5:RM, 6:PM, 7:BM, 8:PB	452A
SV2 Display	RC13	2	WC13_1	1	0:OFF, 1:AL1, 2:AL2, 3:AL3, 4:AL4, 5:RM, 6:PM, 7:BM, 8:PB	452A
Display shutdown timer (Setting of light out time for PV, SV1 and SV2)	RC14	1, 1, 1, 99	WC14_1, 1, 1, 99	1, 1, 1, 99	1:ON, 0:OFF, 0 to 99	452A
	RC14	1, 99	WC14_1, 99	1, 99	1:ON, 0:OFF, 0 to 99	451A
Power On delay	RC40	2	WC40_99	99	2 to 99	452A
Comparison data	RC41	5	WC41_5	5	5:RM, 6:PM, 7:BM, 8:PB	
AL1 Comparison value	RC42	2000	WC42_99999	99999	-99999 to 99999	
AL2 Comparison value	RC43	3000	WC43_99999	99999	-99999 to 99999	
AL3 Comparison value	RC44	7000	WC44_99999	99999	-99999 to 99999	
AL4 Comparison value	RC45	8000	WC45_99999	99999	-99999 to 99999	
AL1 Hysteresis	RC46	1	WC46_9999	9999	1 to 9999	
AL2 Hysteresis	RC47	1	WC47_9999	9999	1 to 9999	
AL3 Hysteresis	RC48	1	WC48_9999	9999	1 to 9999	
AL4 Hysteresis	RC49	1	WC49_9999	9999	1 to 9999	
AL1 Comparison method	RC50	0	WC50_0	0	0:OFF, 1:HI, 2:LO	
AL2 Comparison method	RC51	2	WC51_2	2	0:OFF, 1:HI, 2:LO	
AL3 Comparison method	RC52	1	WC52_1	1	0:OFF, 1:HI, 2:LO	
AL4 Comparison method	RC53	0	WC53_0	0	0:OFF, 1:HI, 2:LO	
Output Delay	RC54	0	WC54_99	99	0 to 99	
Comparison conditions	RC55	0	WC55_1	1	1:GO, 0:NG	
Zone setting	RC56	0	WC56_1	1	1:ON, 0:OFF	
Analog output switching	RC75	5	WC75_6	6	5:RM, 6:PM, 7:BM, 8:PB	Common
Analog output offset	RC78	00000	WC78_99999	99999	-99999 to 99999	
Analog output full scale	RC79	19999	WC79_99999	99999	-99999 to 99999	
Code registration of My setting mode	RC99	42, 43, 44, 45, 01, 02, 03, 00	WC99_42, 43, 44, 45, 01, 02, 03, 00	42, 43, 44, 45, 01, 02, 03, 00	00 to 98	452A
	RC99	01, 02, 03, 00, 00, 00, 00, 00	WC99_01, 02, 03, 00, 00, 00, 00, 00	01, 02, 03, 00, 00, 00, 00, 00		451A

● Measuring command

Function	Requested command		Applicable Model
	Command	Response	
Current value data	DATA?	DATA?	452A 451A
		+_9.9999E+0, 16 +_9.9999E+0	
Current value data	RMREad	+_9.9999E+0	Common
Peak data	PMREad	+_9.9999E+0	
Bottom data	BMREad	+_9.9999E+0	
Amplitude data	PBREad	+_9.9999E+0	

● Judgment command

Function	Requested command			Applicable Model
	Command	Response	Item	
AL1 to AL4, GO	ALARm	16 (00 at ALRESET)	Output Weight of data AL1 01 AL2 02 AL3 04 AL4 08 GO 16	452A

● Control command

Function	Requested command		Specified command			Applicable Model
	Command	Response	Command frame	Response	Item	
Latch	RLATch	1	WLATch 1	1	1:ON, 0:OFF	Common
Hold	RHOLd	0	WHOLd 1	1	1:ON, 0:OFF	
Alarm reset	RALRst	1	WALRst 1	1	1:ON, 0:OFF	452A
Memory reset			MR	End code		Common

● Memory control command

Function	Requested command		Specified command			Applicable Model
	Command	Response	Command frame	Response	Item	
Write			STOR	End code		Common
Default			DEFAult	End code		

Contact Information

Name : Tsuruga Electric Corporation  
 Address : 1-3-23 Minami-Sumiyoshi, Sumiyoshi-ku, Osaka-shi  
 558-0041 Japan

# Quick Manual

## Digital Panel Meter, Model 451A / Meter Relay, Model 452A Decimal Point External Control

I-01689

### 1. Data Output Code

Code	Specifications
EC	Decimal point external control

### 2. Connector and Connections

#### ⚠ WARNING

- To avoid an electrical shock, turn the power off when wiring.
- Do not wire with moistened hands. Locate away from the wet place.
- Do not touch terminals when turning the power on.

#### ⚠ CAUTION

- Do not miswriting. Otherwise, the meter may be broken.

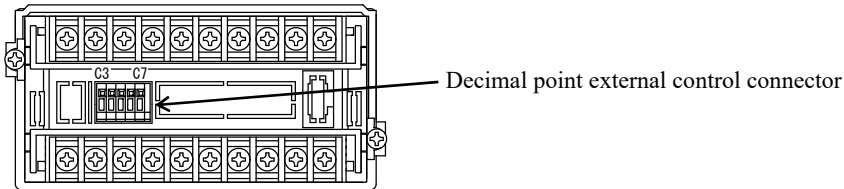

### 2.1 Connections

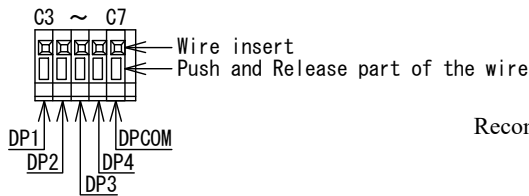

Recommended wire ( Solid wire : AWG28 to 22  
Twisted wire : AWG28 to 22  
O.D. 0.125 min.  
Strip-off length: 9 to 10mm

### 2.2 Specifications

- Setting: Decimal point is programmable from the front panel or external control.
    - Front panel setting: selectable by the front panel key. Refer to the quick manual, I-01593 for the 451A, or I-01594 for the 452A.
    - External control (DP1 to DP4)
- Decimal point is programmable at your desired position by setting the external control mode.  
Short-circuit between  $10^1$  to  $10^4$  digit (DP1 to DP4) and DPCOM (Active "L").  
Decimal point does not light up when overlapping DP1 to DP4 one another.

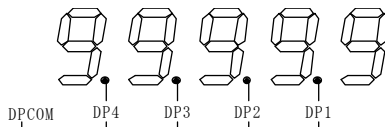

- Electrical specifications: Input terminal and external control terminal are insulated.  
Those are insulated from ZS, MR, and HOLD terminal.  
Active "L",  $I_{IL} \leq -1\text{mA}$ , "L"=0 to 0.8V, "H"=3.5 to 5.0V



### 2.3 Input circuit

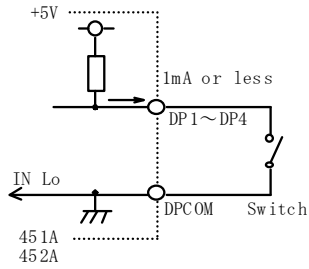

### 2.4 Function

Programmable external control by selecting OUT for the decimal point.

No.	Function	Display	Contents	Default
03	Decimal point	dP.	0, 0.0, 0.00, 0.000, 0.0000, OUT	OUT

### 2.5 Parameter setting mode

During the measuring mode, the display shows “┌ 0 0 0 0” and switches to the parameter setting mode, by pushing the **MODE** key.

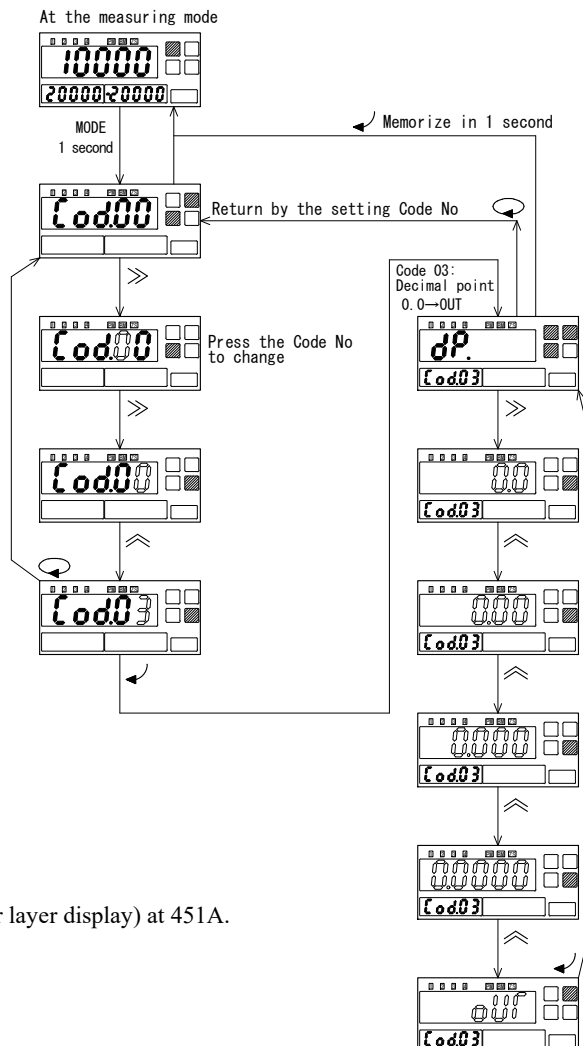

\* No SV display (lower layer display) at 451A.

Contact Information	
Name	: Tsuruga Electric Corporation
Address	: 1-3-23 Minami-Sumiyoshi, Sumiyoshi-ku, Osaka-shi 558-0041 Japan