

FB-00301-2

DRAWING No.

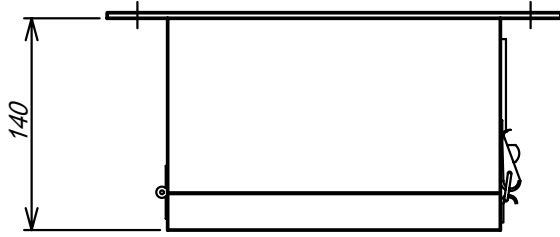

7 segment LED

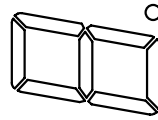

In case of display in 5 digits,
the unit is indicated at

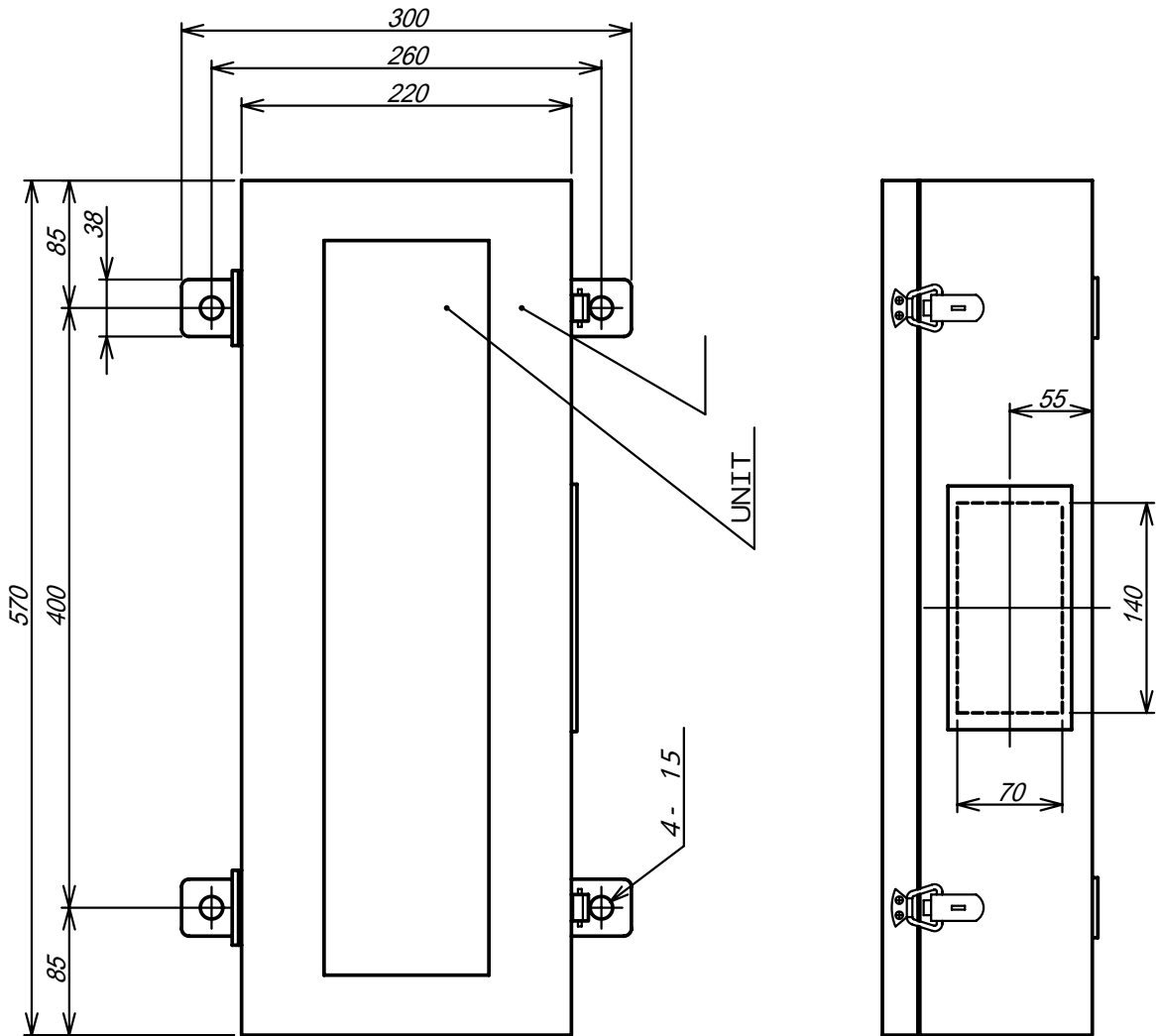

TSURUGA ELECTRIC CORPORATION. All rights reserved.

REVISED	DATE <i>Oct. 22. 1992</i>	APPROVED BY	TITLE
	SCALE 	CHECKED BY	3014-1 - -
May. 21. 2002 全面書き換え K.Y. Apr. 5. 1993	DESIGNED BY	DRAWN BY	DRAWING No.
	TSURUGA ELECTRIC CORPORATION		FB-00301-2

DRAWING No. FB-00304-3

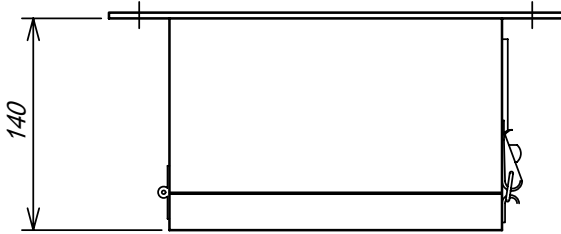

7セグメントLED
7 segment LED

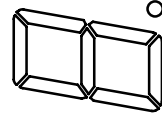

6桁表示の場合、単位は 位置になります。
In case of display in 6 digits,
the unit is indicated at

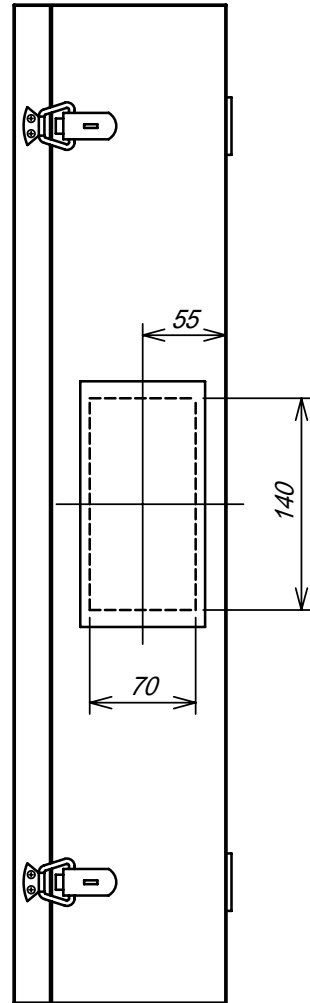
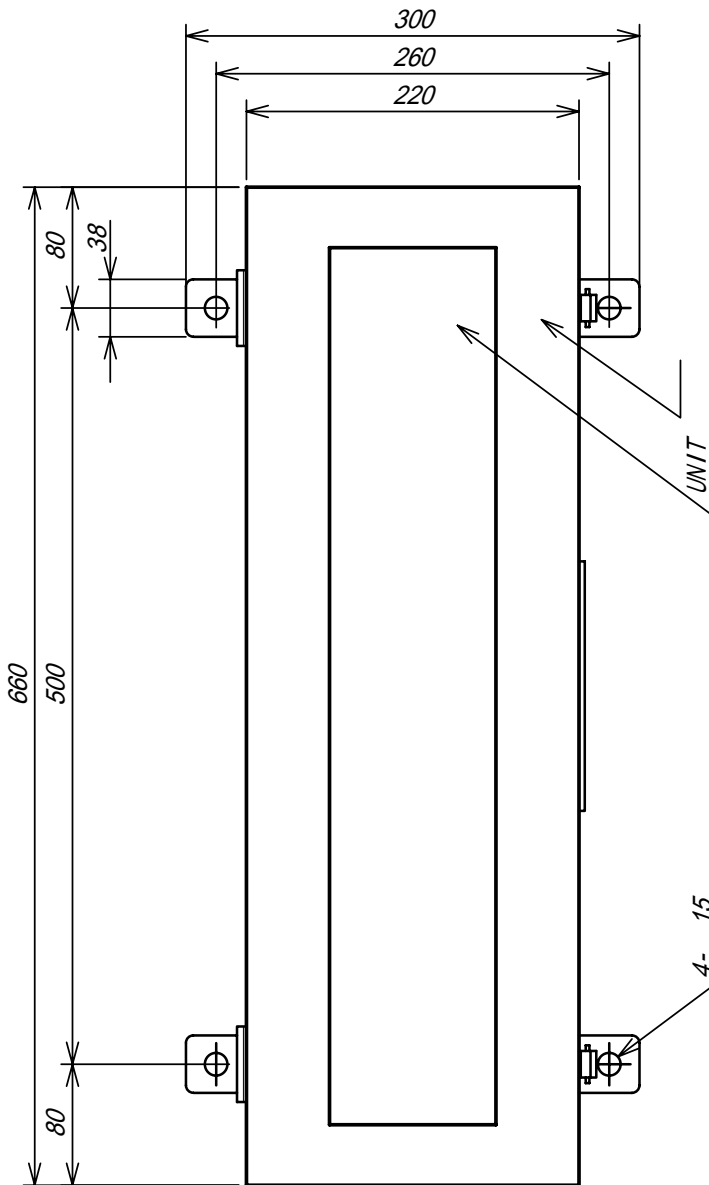

TSURUGA ELECTRIC CORPORATION. All rights reserved.

REVISED	DATE	APPROVED BY	TITLE
	SCALE	CHECKED BY	3014-2 - -
▲ Jan. 21, 2002 ▲ Sep. 27, 1997 ▲ Apr. 5, 1993	DESIGNED BY	DRAWN BY	DRAWING No.
	TSURUGA ELECTRIC CORPORATION		FB-00304-3

DRAWING No. /

TSURUGA ELECTRIC CORPORATION. All Rights Reserved.

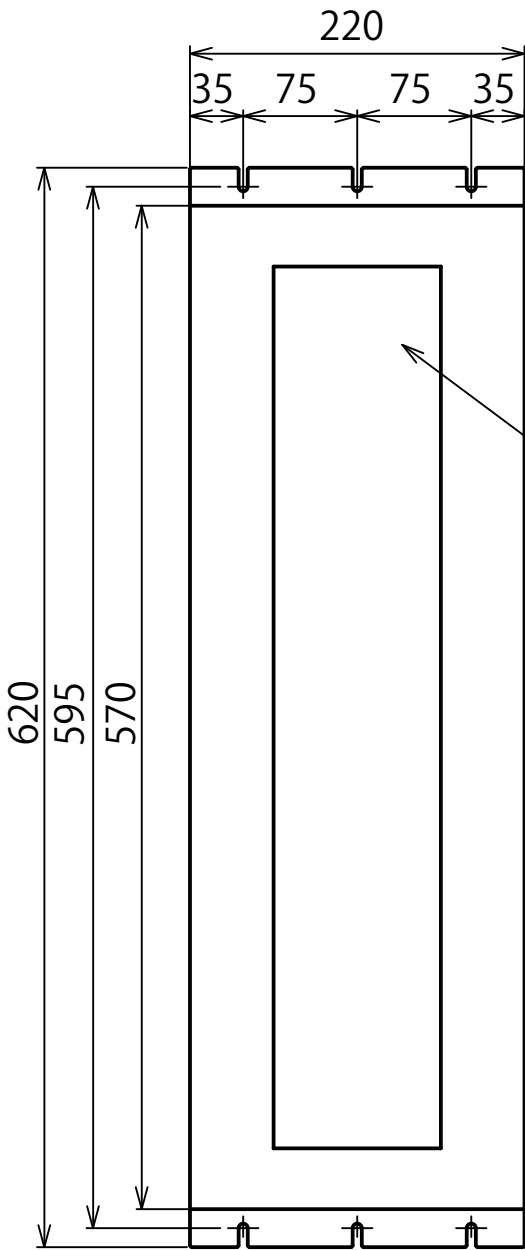
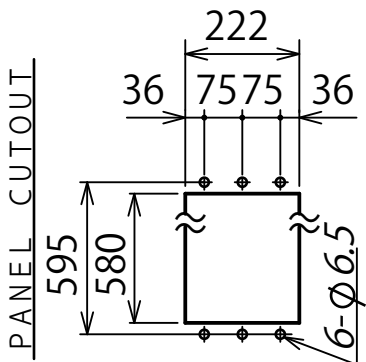
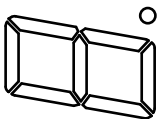
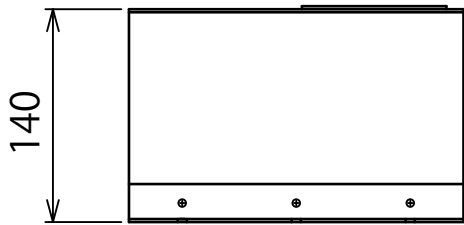

単位

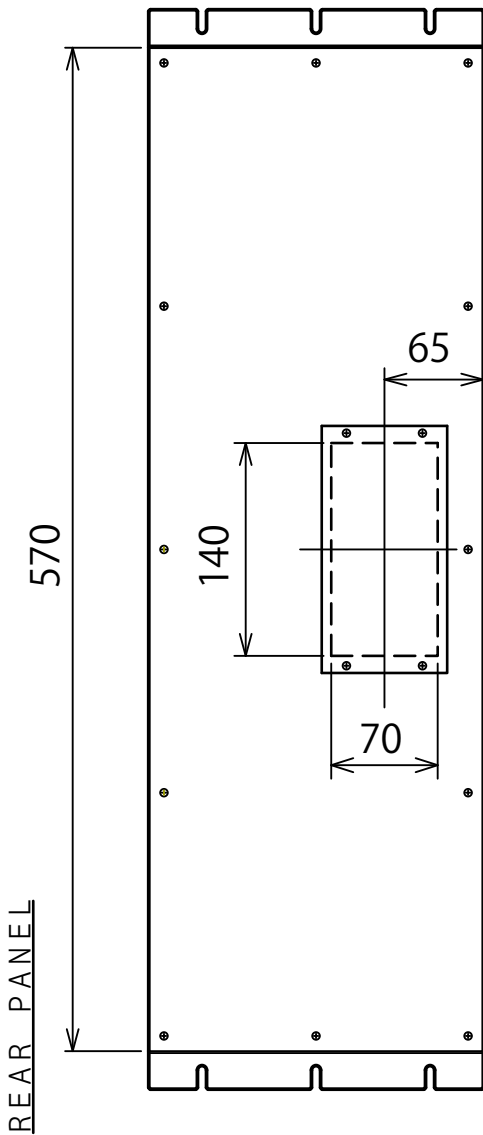

REVISED

DATE

APPROVED BY

TITLE

SCALE

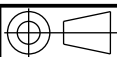

CHECKED BY

3014P-1□-□-□□

DESIGNED BY

DRAWN BY

DRAWING No.

TSURUGA ELECTRIC CORPORATION

FB-00305-3

DRAWING No.

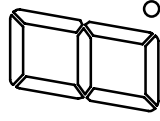
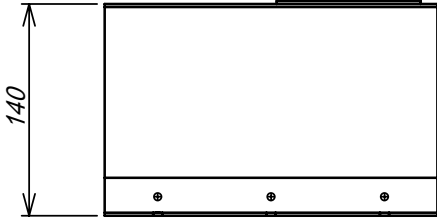

7セグメントLED
7 segment LED

6桁表示の場合、単位は 位置になります。
In case of display in 6 digits,
the unit is indicated at

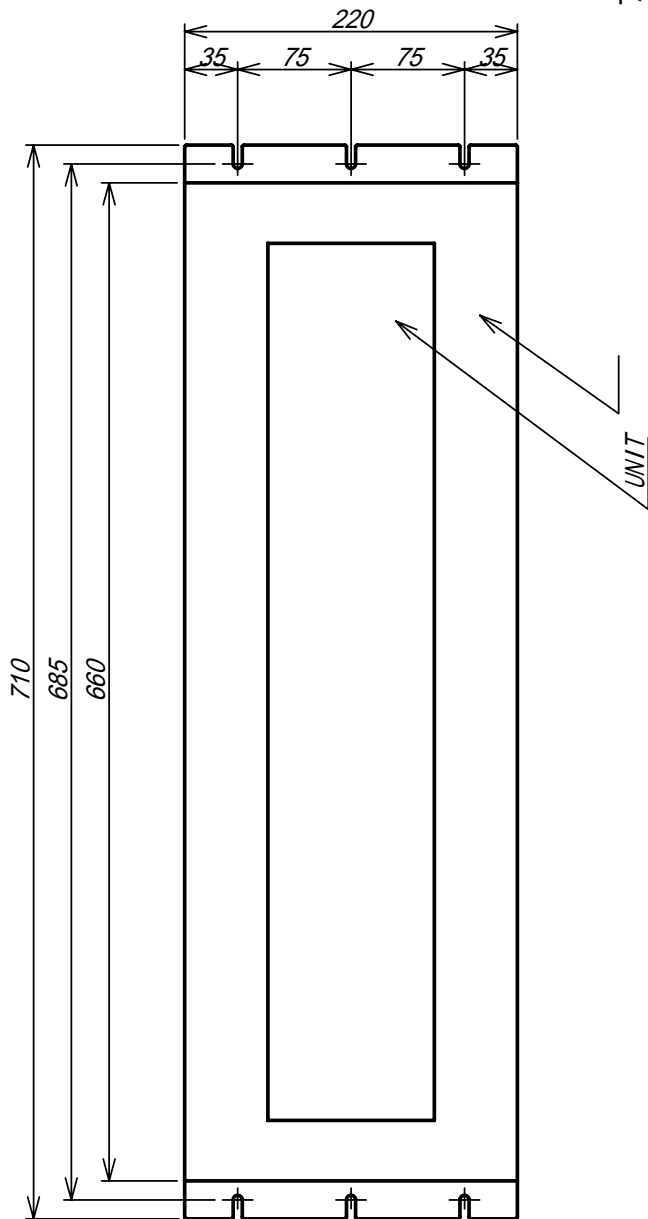
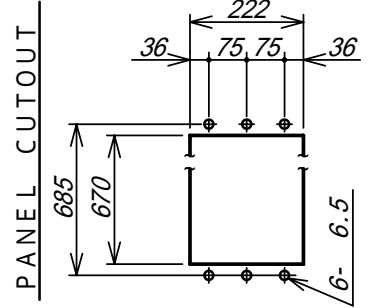

REAR PANEL

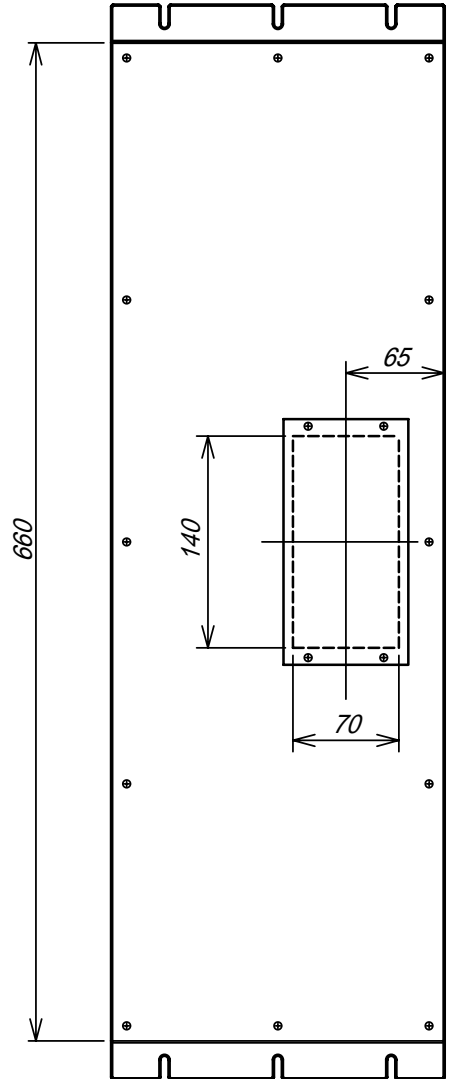

TSURUGA ELECTRIC CORPORATION. All rights reserved.

REVISED

- △ Jan. 21, 2002
- △ Sep. 27, 1997
- △ Apr. 19, 1993

DATE
Oct. 29, 1992

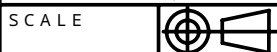

DESIGNED BY

APPROVED BY

CHECKED BY

DRAWN BY

TITLE

3014P-2 - -

DRAWING No.

TSURUGA ELECTRIC CORPORATION

FB-00305-3

DRAWING No.

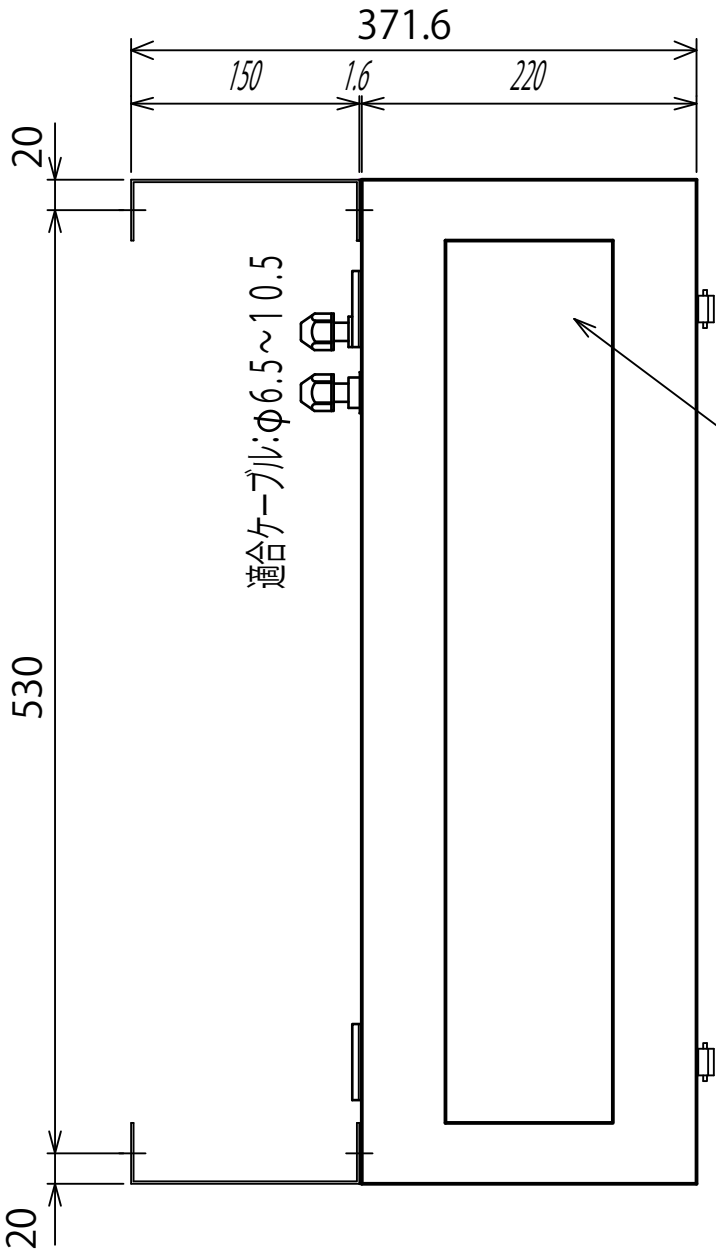
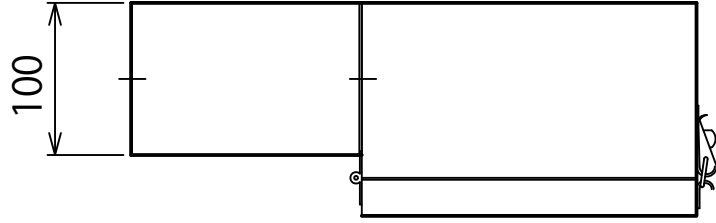
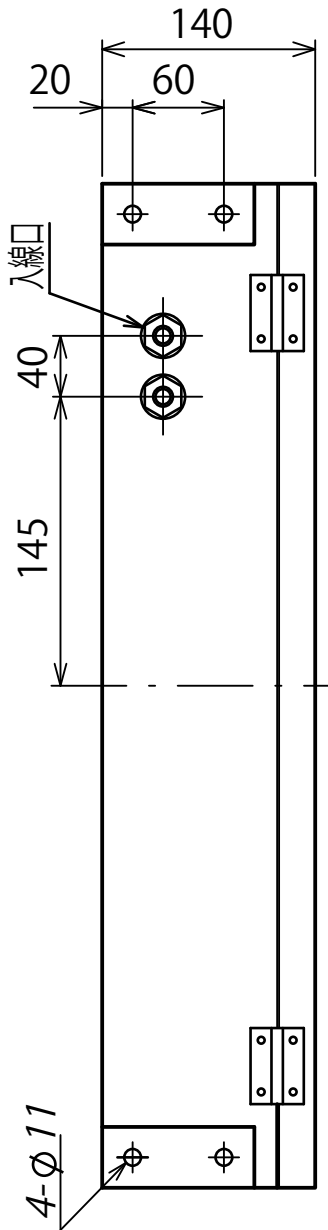

TSURUGA ELECTRIC CORPORATION. All Rights Reserved.

REVISED

DATE

APPROVED BY

TITLE

SCALE

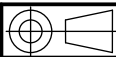

CHECKED BY

3014H-1□-□-□□

DESIGNED BY

DRAWN BY

DRAWING No.

TSURUGA ELECTRIC CORPORATION

引込口の適合ケーブル外径 6.5~10.5
 Intaking conduit
 Conformable cable
 6.5~10.5

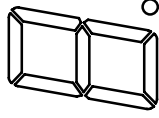

7セグメントLED
 7 segment LED

6桁表示の場合、単位は 位置になります。
 In case of display in 6 digits,
 the unit is indicated at

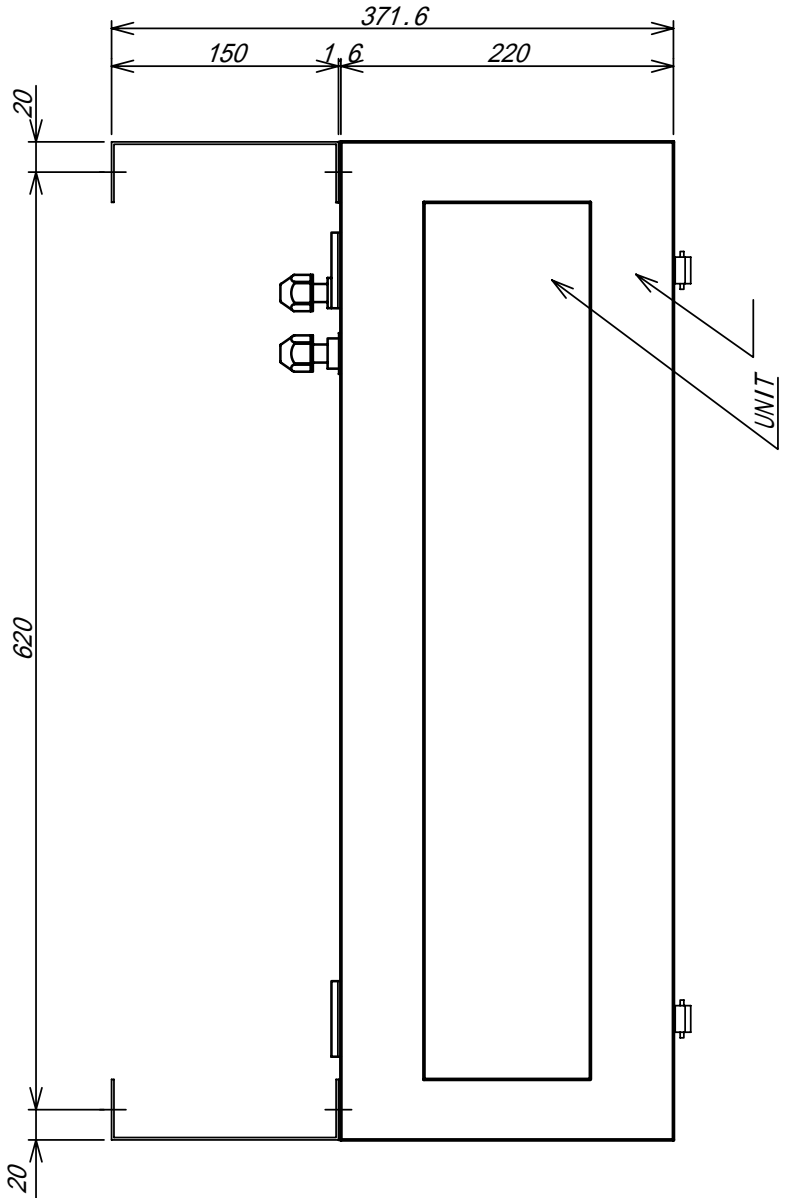
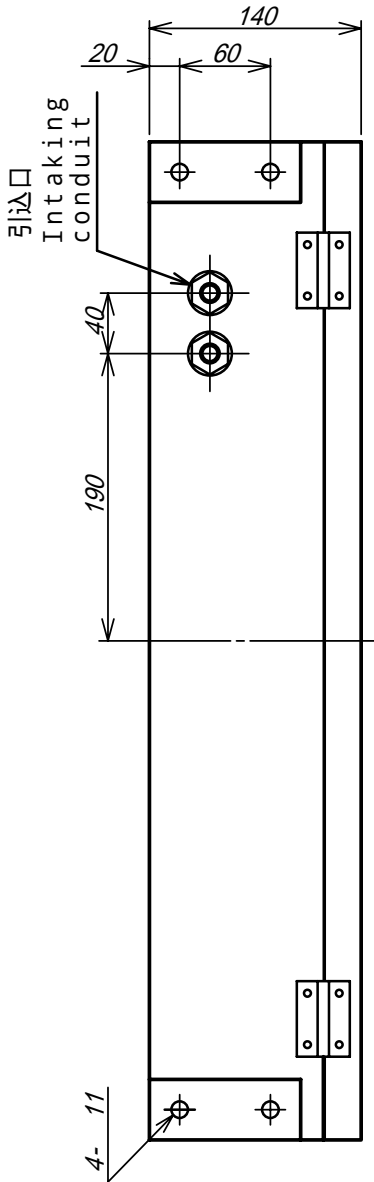
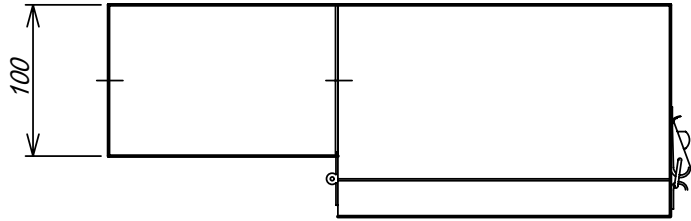

REVISED

- ⚠ Jan. 21, 2002
- ⚠ Sep. 27, 1997
- ⚠ Apr. 12, 1993

DATE **Oct. 29, 1992**



DESIGNED BY

APPROVED BY

CHECKED BY

DRAWN BY

TITLE

3014H-2 - -

DRAWING No.

TSURUGA ELECTRIC CORPORATION

FB-00306-3